

Solving the Bracketing Paradox: An Analysis of the Morphology of German Particle Verbs*

Stefan Müller

Language Technology Lab, DFKI GmbH, Saarbrücken, Germany

March 14, 2003

Abstract

Inflectional affixes are sensitive to morphological properties of the stems of the verbs they attach to. Therefore it is reasonable to assume that the inflectional material is combined with both the verbal stem of simplex verbs and the verbal stem of particle verbs. It has been argued that this leads to a bracketing paradox in the case of particle verbs since the semantic contribution of the inflectional information scopes over the complete particle verb. I will discuss nominalizations and adjective derivation, which are also problematic because of various bracketing paradoxes. I will suggest a solution to these paradoxes that assumes that inflectional and derivational prefixes and suffixes always attach to a form of a stem that contains the information about a possible particle already, but without containing a phonological realization of the particle. As is motivated by syntactic properties of particle verbs, the particle is treated as a dependent of the verb. The particle is combined with its head after inflection and derivation. With such an approach no special mechanisms for the analysis of particle verbs are necessary.

1 Introduction

In German there is a class of verbs—the so-called particle verbs—that can appear discontinuously both in syntax (1) and morphology (2).

- (1) (a) Setzt der Fährmann Karl über?
 takes the ferryman Karl across
 ‘Does the ferryman take Karl across?’

*I gave talks about the morphology of German particle verbs in Tübingen at the Seminar für Sprachwissenschaft, in Stuttgart at the Institut für maschinelle Sprachverarbeitung (IMS), in Potsdam at the Institut für Linguistik/Allgemeine Sprachwissenschaft and at the HPSG’2001 conference in Trondheim. I thank Tübingen, Stuttgart, and Potsdam for the invitation and the audiences of all four talks for discussion. Thanks to Berthold Crysmann, Kordula De Kuthy, Peter Gallmann, Anke Lüdeling, and Andrew McIntyre, Christine Römer, and Hans Uszkoreit for discussion, two anonymous reviewers for comments, and to Kordula De Kuthy, Detmar Meurers, Nicole Dehé, and Anke Lüdeling for supplying me with relevant literature. Thorsten Brants helped me to find the examples that are from the NEGRA corpus. I want also to thank Uta Waller who helped me translate sample sentences from newspapers. The research carried out for this paper was supported by a research grant from the German Bundesministerium für Bildung, Wissenschaft, Forschung und Technologie (BMBF) to the DFKI project WHITEBOARD (‘Multilevel Annotation for Dynamic Free Text Processing’), FKZ 01 IW 002. The paper was completed at the Institut für Germanistische Sprachwissenschaft of the Friedrich Schiller University Jena.

- (b) daß der Fährmann Karl übersetzt.
that the ferryman Karl across.takes

In (1a), where the verb is in initial position, the particle is stranded. It is serialized to the right of non-extraposed complements and adjuncts.

The noun in (2b) is an example of derivational morphology where the *ge-* prefix of the discontinuous *Ge-* *-e*-nominalization separates particle and verbal stem.

- (2) (a) Er rennt herum.
he runs around
(b) das Herumgerenne
the around.running
'the running around'

Ge- *-e*-nominalizations of particle verbs can be input to further morphological processes as is shown by examples like (3) which supports the view that these nominalizations are formed in the morphology component.

- (3) das Pseudo-Herumgerede¹
the pseudo.babble

The interesting fact about nominalizations like the one in (2b) is that the semantic contribution of the *ge-* *-e* scopes over the semantic contribution of the complete particle verb thus yielding a morphosemantic paradox.

In this paper I want to discuss several bracketing paradoxes of similar kind and will show how the problem of these apparent paradoxes can be solved. The analysis of the inflectional and derivational morphology of particle verb combinations is based on the analysis of the syntax of particle verb combinations that was developed by Müller (2000).

The paper is structured as follows: In the next section I discuss apparent bracketing paradoxes from inflectional and derivational morphology. In section 3, I give a very brief introduction to the analysis of verbal complexes in German in the framework of Head-Driven Phrase Structure Grammar that was developed by Pollard & Sag (1994). In section 4, I repeat the analysis of particle verb combinations in syntax that was suggested by Müller (2000) and in section 5, I will show how the morphological facts are explained in such a set-up. In section 6, I discuss alternative proposals.

2 The Phenomenon

The morphological facts that will be discussed in the following subsections suggest that inflectional and derivational material always attaches to the verbal stem in verb particle combinations. On the other hand, this material always scopes over the meaning contribution of the complete particle verb or requires a certain argument structure that is not present in the base verb, but only in the particle verb.

In the following subsection I discuss the first apparent paradox that arises in inflectional morphology.

¹Stiebels (1996, p. 40)

2.1 Inflection

Particle verbs always have the same inflection class as their base verb. This means that the inflectional suffix has to have access to the morphological features of the stem. This is accounted for easily in an analysis where inflectional material is combined with the stem before the particle is added, i.e., with a structure like the one in figure 1a. Bierwisch (1987, p. 163) argues that the meaning of the verb *aufhören* ('end') is not



Figure 1: Alternative Structures for *aufhören*

transparent with regard to the combination of *auf* and *hör-*, but combinations of the form *auf-hör-t-est* and *auf-ge-hör-t* are transparent with regard to the combination of the meaning *end* and the conceptual content of the inflectional affixes. He claims that one needs structures like the one in figure 1b because of this, and hence he has a structural paradox. Bierwisch (1987, p. 165), Stiebels & Wunderlich (1994, p. 934), and Stiebels (1996, p. 46) suggest rebracketing mechanisms to derive the structure in figure 1a from the one in figure 1b. However, this paradox is not a real one, since the situation with idioms is similar as far as compositionality is concerned.² It is not justified that a head that is part of an idiomatic expression is combined with all parts of the idiom before it is inflected. So one can stick to the structure in figure 1a; assuming that the semantics of non-transparent particle verbs is constructed parallel to the semantics of (a certain class of) idioms.

For transparent particle verb combinations I also assume the structure in figure 1a. I assume that the inflectional affix attaches to a stem that contains the information that it will combine with a particle, i.e., a stem that is subcategorized for a particle. This stem is licensed by a lexical rule that maps a simplex verb to a verb that selects a particle. The lexical rule is motivated by an analysis of syntactic properties of particle verbs and will be explained in section 4. The stem that is licensed by the rule has the meaning of the complete particle verb combination although the exact meaning is not fully instantiated until the particle combines with the (inflected) stem. Since the semantic information that will be contributed by the particle is accessible in the stem entry already, the ending can scope over it.

The exact details of this analysis will be made more precise once we have introduced the formal apparatus.

²Bierwisch (1987, p. 166) gives examples from compounding that suggest that rebracketing may be needed and, of course, there are famous examples of a similar kind from English; but for the cases at hand a rebracketing mechanism is not necessary as will be shown in section 5.

Stump (1991) discusses a wide variety of morphosemantic mismatches in English, Breton, Georgian, and Sanskrit and suggests paradigm functions that allow inflectional or derivational material to attach to a head that is contained inside other material, i.e., he assumes a structure like the one in figure 1b. I will discuss his approach in section 6.2.

For an analysis of the *transformational grammarian* paradox see Spencer (1988).

2.2 Derivation

Similar bracketing paradoxes seem to arise in derivational morphology. Some derivational affixes are sensitive to the argument structure of the head they combine with and some others are sensitive to the semantics of the heads they combine with, some affixes are sensitive to both kinds of properties. In sections 2.2.1 and 2.2.2, I will examine the relevant forms of nominalization and adjective formation.

2.2.1 *Ge-* *-e*-Nominalizations

The *Ge-* *-e*-nominalization is the only discontinuous or combinatorial noun derivation in German; it consists of the prefix *Ge-* and the suffix *-e*. The suffix *-e* can be used optionally following the unstressed syllables *-er*, *-el*, *-en* where it is usually suppressed for phonological reasons (*Rumgeeiere*³ vs. *Rumgeeier*⁴) (see Olsen (1991, p. 351)). *Ge-* *-e*-derivation is quite productive for transitive as well as for intransitive simplex verbs. Deverbal *Ge-* *-e*-nouns have the meaning of ‘constant/repeated V-ing’ and usually they have the connotation that the constant V-ing is somehow negatively evaluated.

Particle verbs also allow for *Ge-* *-e*-derivation. It is interesting that the *ge-* separates particle and base verb: *Herumgerenne* (‘repeated aimless running’). *Ge-* *-e*-nominalizations of particle verbs with the particle *herum* (‘around’) follow a productive pattern and are quite frequent.

As Lüdeling (2001, p. 106) notes, the interesting thing about these *Ge-* *-e*-nominalizations is that there again seems to be a bracketing paradox: If one combines the stem *renn-* with *Ge-* and *-e* one gets *Gerenne*, which means ‘repeated or constant running’, or more technically ‘repeated running events’. However, *Herumgerenne* means ‘repeated instances of aimless running events’. The ‘aimless’ part of the meaning is contributed by *herum*.⁵ This meaning of *Herumgerenne* would be expected if the *Ge-* *-e* were combined with the whole particle verb combination.

Lüdeling considers for a moment an account where an abstract predicate is added to the semantic contribution of *rennen*, but dismisses this suggestion since, according to her, this solution would not extend to listed particle verb combinations. I do not understand this argumentation, since the non-transparent forms are always the unproblematic ones in terms of scope relations. A lexical item that is subcategorized for a particle can be listed in the lexicon and the meaning contribution of the complete non-transparent particle verb is represented in this lexical item. Lüdeling suggests the analysis in fig-

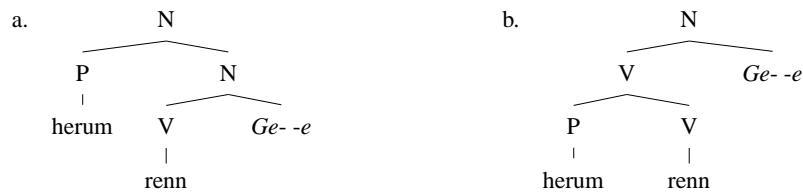

Figure 2: Alternative Structures for *Herumgerenne*

ure 2b. It is unclear how the prefix *ge-* is supposed to get in-between the particle and

³Frankfurter Rundschau, 05.12.1998, p. 1

⁴Frankfurter Rundschau, 29.09.1998, p. 3

⁵This is not the only meaning that *herum* has. For other meanings and a way to express them formally see McIntyre (2001a,b).

the verb without the assumption of rebracketing. In what follows I will assume the structure in figure 2a. I assume that the stem *renn-* that is used to derive *Herumgerenne* already contains the information that it combines with a particle, although the exact semantic and syntactic contribution of the particle is still underspecified. The *Ge-* *-e-* nominalization can therefore access the semantic contribution that will be instantiated by the particle and the right scope relations can be established.

Note that I do not claim that nouns like *Herumgerenne* are the result of compounding the *Ge-* *-e-* nominalization of the simplex verb *renn-* with *herum* since—as McIntyre (2001c, p. 22) showed—double particles like *herum* do not appear in normal compounds: *herumkritisieren* vs. **Herumkritik*.

2.2.2 Adjective Derivation with *-bar*

-bar-derivation applies to transitive or ditransitive verbs that have an accusative object. The logical subject of the verb is suppressed and the accusative object is promoted to the subject of the adjective. There are also a few *-bar*-adjectives like *brennbar* (‘flammable’) that have an intransitive base verb, but these are listed in the lexicon (Riehemann, 1998) and not derived by the productive rules. The *-bar*-suffix adds a modal meaning, usually possibility, but sometimes also necessity.

Lüdeling (2001, p. 108) remarks that most of the *-bar*-derivations are derivations of listed particle verb combinations.⁶ She compares coordinated structures with *-bar*-derivations of particle verb combinations that have both a non-transparent and a transparent reading and concludes that only the derivations from non-transparent particle verbs are well-formed. She discusses the examples in (4) and (5) which show that *anbaubar* can only be formed with the fully lexicalized variant *to cultivate* although the passive of *anbauen* + *können* with the meaning *to build onto*, *to add* in the first part of (4b) is grammatical. A similar contrast holds for (5a) and (5b).

- (4) (a) Können in Deutschland Bananen angebaut werden oder sind sie hier
 can in Germany bananas cultivated be or are they here
 nicht anbaubar?
 not growable
 ‘Is it possible to cultivate bananas in Germany or can’t they be grown here?’
- (b) * Kann der Schuppen hier angebaut werden oder ist er hier nicht
 can the shed here added be or is it here not
 anbaubar?
 add+able
 Intended: ‘Can the shed be built as an extension here or can’t an extension be built here?’

⁶Lüdeling (2001, p. 84) defines listedness in the following way: A simple or complex linguistic expression is listed, iff all terminal nodes are associated with phonological information.

This definition means that the lexicon may consist of trees. Such a definition only makes sense for grammar models that assume operations on trees, since without such operations it cannot be explained why parts of a listed expression can be extracted. On particle extraction see section 4.1. One can define listedness in a more theory neutral way: A complex linguistic expression is listed, iff the phonological form of its parts is specified.

- (5) (a) Kann dieser Kandidat aufgestellt werden oder ist er nicht
 can this candidate nominated be or is he not
 aufstellbar?
 nominatable+able
 ‘Is it possible to put up this candidate or can he not be put up?’
- (b) ?? Kann der Weihnachtsbaum hier aufgestellt werden oder ist er hier
 can the Christmas.tree here up.put be or is it here
 nicht aufstellbar?
 not up.put+able
 Intended: ‘Can the Christmas tree be put up here or is it impossible to put
 it up here?’

While this data is interesting, its interpretation is not correct. The only thing it shows is that the use of the *-bar*-derivations of a productive form seems to be strange if a *-bar*-derivation from a non-transparent particle verb is also available. The examples in (6) and (9) show that *-bar*-derivation is also possible with transparent particle verb combinations that follow a productive pattern.

Stiebels (1996) discusses six forms of the particle *an* that have different syntactic and semantic properties. To be able to talk about the different instances of this particle she assigns indices to the various forms. The *an* in (6) is Stiebels’ *an*₅ (Stiebels, 1996, Chapter 7.4.1).

- (6) (a) „Die Kneipen, Theater und Geschäfte müssen **anfahrbare** bleiben.“⁷
 the pubs theaters and shops must PART (to).drivable remain
 ‘The pubs, theaters and shops must remain accessible by car.’
- (b) Flughafen Schönefeld jetzt bei jedem Wetter **anfliegbare**⁸
 airport Schönefeld now at all weather PART (to).flyable
 ‘Airport Schönefeld can now be accessed by plane in any weather.’
- (c) Im ebenfalls unter dieser Adresse **ansteuerbare**
 in.the equally under this address PART (to).steerable
 Diskussionsforum erntete diese Dienstleistung aber helle Empörung.⁹
 discussion.forum harvested this service but light indignation
 ‘However, in the discussion forum which can also be accessed under this
 address, this service was strongly criticized.’
- (d) Dauerläufer, die in der Defensive ackern, ständig
 continuous.runners who in the defensive slug.away always
anspielbar sind [...] ¹⁰
 PART (to).playable are
 ‘Those who never stop running, slug away in the defense, are always ready
 for the ball’

This *an* expresses that the action that is described by the base verb is directed to a thing or a person. The particle can be combined with intransitive agentive verbs. This pattern is highly productive. Examples are verbs of uttering (7) and verbs that are used to express emotions (8).

⁷taz, 05.06.1997, p. 22. The *taz* is a newspaper that appears nation-wide in Germany (<http://www.taz.de>).

⁸taz, berlin, 04.02.1992, p. 22

⁹taz, 08.07.1999, p. 13

¹⁰taz, 22.02.1999, p. 16

- (7) (a) Er quatscht sie an.
 he gabs her PART (to)
 ‘He chats her up.’
- (b) Sie schrien ihre Nachbarn an.
 they shout their neighbors PART (to)
 ‘They shout at their neighbors.’
- (c) Die Katze faucht Andreas an.
 the cat hisses Andreas PART (to)
 ‘The cat spits at Andreas.’
- (8) (a) Sie lacht ihn an.
 she laughs him PART (to)
 ‘She smiles at him.’
- (b) Er schmachtet die große Diva an.
 he gazes. lovingly the great diva PART (at)
 ‘He gazes at the great diva adoringly.’
- (c) Er staunt den Akrobaten / den Dom an.
 he marvels the acrobat the cathedral at
 ‘He marvels at the acrobat / the cathedral.’

The *an* in (9) is Stiebels’ *an*₆ (Stiebels, 1996, Chapter 5.2.3).

- (9) Das Konzept sei zwar „grundsätzlich **andenkbar**“.¹¹
 the concept be actually in.principle PART.thinkable
 ‘In principle it is possible to start thinking about the concept.’

This version of *an* is the most productive one of the particles and prefixes Stiebels examined in her study. The *an* expresses a partiality of the action that is described by the main verb. It can be combined with verbs that describe incremental or decremental processes, which makes an early termination plausible. The group of *an*-verbs can be divided into those where the *an* expresses a spatial relation: *anbohren* (‘to begin to bore a hole’), *anknabbern* (‘to nibble’), *anlecken* (‘to (begin) to lick’), *annagen* (‘to (begin) to gnaw’), and those where the *an* is a progressive marker: *andrukken* (‘to start to print’), *anlesen* (‘to begin to read’), *ansingen* (‘to begin to sing’).

Concluding the discussion of *-bar*-derivations with particle verbs with *an*, it can be said that it is possible with productive particle verb combination patterns.

Before I turn to the bracketing paradox of *-bar*-derivation, let us have a look on particle verb combinations like *anfahren* (‘to drive towards’). The noun phrase *die Geschäfte* (‘the shops’) in (10c) is licensed by the particle *an*₅. As (10b) shows *die Geschäfte* is not an argument of *fahren*.

- (10) (a) Er fährt.
 he drives
- (b) * Er fährt die Geschäfte.
 he drives the shops
- (c) Er fährt die Geschäfte an.
 he drives the shops towards
 ‘He drives towards the shops.’

¹¹taz, 06.11.1997, p. 2

Rather the intransitive version of *fahren* that is used in (10a) is combined with the particle.

Having established that particle verb combinations that are the result of a productive process can take part in *-bar*-derivations, I am faced with another apparent bracketing paradox: There are particles like *an*₅ that only combine with intransitive verbs and add another argument. On the other hand, *-bar* only combines with transitive verbs productively. If one assumes the structure in figure 3a with *fahr-* being the stem of the intransitive version of *fahren*, one has to explain why *-bar* can combine with intransitive verbs. Furthermore, the modal operator that is contributed by *-bar* scopes over the complete meaning of the particle verb. In the light of pairs like (11), the structure in figure 3a seems implausible, since there is no way of deriving the meaning of the second word from the meaning of the first:

- (11) (a) schaffbar ('do-able') → wegschaffbar ('possible to be got rid of', 'disposable')
 (b) greifbar ('reachable') → angreifbar ('possible to be attacked')
 (c) stellbar ('possible to stand/set up') → darstellbar ('possible to be represented', 'representable'), einstellbar ('possible to set', 'employable'), herstellbar ('possible to manufacture'), vorstellbar ('imaginable')

Even worse, a *bar*-adjective without particle does not exist for the examples in (12).

- (12) (a) *gleichbar → ausgleichbar ('possible to even out')
 (b) *weisbar → nachweisbar ('possible to prove')

At first glance figure 3b seems to be the only option. Bierwisch (1987) and Stiebels & Wunderlich (1994) assume a uniform analysis for inflectional and derivational morphology of particle verbs where the inflectional and derivational material attaches directly to the verbal stem, i.e., the structure in figure 3a. Since an analysis that treats inflection and derivation in a uniform way rather than stipulating different structures for various morphological phenomena on a case by case basis is to be preferred, I also assume the structure in figure 3a. While this may seem to be problematic for the rea-

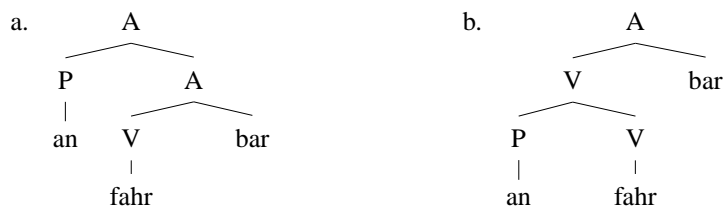

Figure 3: Alternative Structures for *anfahrbar* ('reachable by car')

sons mentioned above, it is not in constraint-based theories. I assume that the stem in figure 3a contains a slot for the particle that will be added in a later step. The valence and the semantics of the whole combination is represented at the stem of the particle verb so that *-bar* may access it.

2.3 Non-Existing Bases

It has been noted by many researchers that there are particle verbs that have a base verb that cannot be used without the particle (for instance *anstrengen* ('to strain') and

* *strengen*).

Similarly there are particle verb formations (13a) and derivations (13b,c) where the derived base never appears without particle.

- (13) (a) *Dose* ('tin'), *eindosen* ('to tin'), but * *dosen*
(b) *rauben* ('to steal'), *ausrauben* ('to rob'), *Ausraubung* ('robbing'), but * *Raubung*¹²
(c) *ausbreiten* ('to spread out'), but * *breiten*, *Ausbreitung* ('out-spreading'), but * *Breitung*¹³

This does not pose a problem if one assumes that the derivation applies to the linguistic object that represents the particle verb. So if the *-ung*-nominalization applies to a lexical representation for *raub-* that contains the information that there will be a particle, the constraints that block the derivation of * *Raubung* from the simplex base *raub-* do not apply to this lexical entry and the derivation succeeds. For the same reason it is not necessary to list * *strengen* in the lexicon as a verb that could appear without a particle: The lexicon contains a lexical entry for the verb stem *streng-* that selects the particle *an*. The stem is inflected and after inflection it is combined with the particle.

2.4 Conclusions

Inflectional affixes like *ge-* *-t* in *auf-ge-hör-t* and derivational affixes like *Ge-* *-e* in *Herum-ge-renn-e* attach to the stem of the verb, although they scope over the meaning of the complete particle verb combination. A uniform treatment of both inflection and all derivations of particle verbs, i.e., an approach where the affixes always attach to the verbal stem before the combination of particle and verb, is to be preferred over an approach that assigns structures on a case by case basis. An analysis that assumes that inflection and derivation applies to stems that contain the information about particles to be added later makes the right predictions without any bracketing paradox and copes with the problem of non-existing bases.

3 The Verbal Complex

In this section, I explain the analysis of the verbal complex. The analysis of the verbal complex is relevant in the context of this paper since the analysis of particle verbs that is provided in section 4 uses basic techniques that have been developed for the analysis of verbal complexes. Furthermore, I follow Müller (2000) in assuming that the particle in particle verb constructions should be analyzed as part of the predicate complex.

On the basis of fronting data and auxiliary flip examples like those in (14) and (15), Hinrichs & Nakazawa (1989) argued that auxiliaries and modals form a predicate complex with the main verbs in German.

- (14) Geholfen haben wird er dem Mann.
helped have will he the man
'He probably helped the man.'

Since German is assumed to be a verb second language, i.e., a language with exactly one constituent before the finite verb, examples like (14) are evidence for the existence of the constituent *geholfen haben*.

¹²Fleischer & Barz (1995, p. 173)

¹³Paul (1920, p. 75)

- (15) (a) daß er dem Mann helfen müssen wird.
 that he the man help must will
 ‘that he will have to help the man.’
 (b) daß er dem Mann wird helfen müssen.
 that he the man will help must
 ‘that he will have to help the man.’

The examples in (15) are explained easily by an analysis that assumes that *helfen* forms a complex with *müssen* and the result is embedded under *wird* which is serialized either to the right or to the left of the embedded complex.

In Hinrichs and Nakazawa’s analysis *helfen* (‘help’) and the auxiliary *wird* (‘will’) form a verbal complex in examples like (16).

- (16) daß er dem Mann [helfen wird].
 that he the man help will
 ‘that he will help the man.’

When a verbal complex is formed, two verbs are combined and the resulting verbal complex inherits all arguments from both verbs. The resulting projection functions as a complex head.¹⁴

In their paper, Hinrichs and Nakazawa treat verbal complements as ordinary complements that are included in the SUBCAT list of their heads. It has, however, proven to be useful to distinguish the verbal complement from other complements (Chung, 1993; Rentier, 1994; Müller, 1997; Kathol, 1998). For the purpose of representing the information about complements that form a predicate complex with their head, the feature VCOMP is introduced. Its value is a list that contains a *synsem* object if the verb selects for a dependent to form a complex with, and the empty list otherwise.

The description in (17) shows the CAT value for the stem entry of the future tense auxiliary *werden*.¹⁵

- (17) *werden* (‘will’, future tense auxiliary):
- $$\left[\begin{array}{l} \text{HEAD } \textit{verb} \\ \text{SUBCAT } \square \\ \text{VCOMP } \langle \text{V}[\textit{bse}, \text{SUBCAT } \square, \text{VCOMP } \langle \rangle] \rangle \end{array} \right]$$

Werden selects a verb or a verbal complex via VCOMP. All arguments of this verbal complex (\square) are raised.¹⁶ The instantiations of the list \square may be the empty list. *Werden* does not assign thematic roles to dependents of the embedded verb. Therefore no reference to elements possibly contained in SUBCAT is necessary.

Lexical entries for the perfect auxiliaries (*haben/sein*) are completely analogous to (17) except for the verb form of the selected verbal complex.

¹⁴See also Bierwisch (1990) and Haider (1993) for similar analyses formulated in the GB framework.

¹⁵For explanatory purposes, I assume that both subjects and complements are represented on the SUBCAT list. The issues discussed in this paper are orthogonal to the representation of the subject. Representations like the ones suggested in Pollard & Sag (1994, Chapter 9), Kiss (1995), or Pollard (1996) are also compatible with the analysis.

¹⁶The lexical entry as given in (17) admits multiple analyses of sentences containing this auxiliary since it is not specified that the verb that is embedded has to be lexical. Since it is not relevant for the rest of this paper, I omitted the necessary specifications in lexical entries and in Schema 1.

As Hinrichs & Nakazawa (1994) have shown, it is reasonable to assume a schema that licenses the verbal complex in addition to the head complement schema. In the following I use the schema 1 which licenses head cluster structures.

Schema 1 (Cluster Schema)

$$\text{head-cluster-structure} \rightarrow \left[\begin{array}{l} \text{SYNSEM|LOC|CAT|VCOMP } \boxed{1} \\ \text{HEAD-DTR|SYNSEM|LOC|CAT|VCOMP } \boxed{1} \oplus \langle \boxed{2} \rangle \\ \text{NON-HEAD-DTRS } \langle [\text{SYNSEM } \boxed{2}] \rangle \end{array} \right]$$

A head is combined with its verbal complement ($\boxed{2}$). The remainder of the VCOMP list ($\boxed{1}$) is passed up to the mother node. In our example $\boxed{1}$ will be the empty list. The specification of the VCOMP value of the verbal complement of verbs like *werden* ('will') as the empty list ensures that the verbal complex that is embedded under *werden* is complete, i.e., sentences like (18b), where the verb under *haben* ('to have') is missing, are ruled out.

- (18) (a) daß er dem Mann [[geholfen haben] wird].
 that he the man helped have will
 ‘that he will have helped the man.’
 (b) * daß er dem Mann haben wird.
 that he the man have will

How the analysis of the verbal complex in (16) works in detail is shown in figure 4 on the next page.¹⁷ The future auxiliary *wird* embeds the infinitive *helfen* (a verb with VFORM *bse*). Since no complements get saturated in head-cluster-structures, the SUBCAT list of the head is identical to the SUBCAT list of the mother. Because of this constraint, the SUBCAT list of *helfen wird* ('help will') is identical to the SUBCAT list of *wird*. *helfen wird* is a complex head that is combined with its arguments in normal head complement structures.

After this brief explanation of the analysis of German verbal complexes, I now sketch the analysis of particle verb combinations.

4 The Syntax of Particle Verb Combinations

In Müller (2000, 2002), I show that it seems reasonable to treat particles as elements that take part in predicate complex formation.¹⁸ In these publications, I provide fronting data and linearization data, some of which will be presented in condensed form in sections 4.1 and 4.2, respectively.

¹⁷The *str* in the lexical entry for *helfen* stands for structural case. Structural case is assigned by a Case Principle that is similar to the one suggested by Yip, Maling & Jackendoff (1987): In verbal environments the first NP in the SUBCAT list that has structural case is realized as nominative and the second NP with structural case is realized as accusative. For a formalization of the Case Principle see Przepiórkowski, 1999; Meurers, 1999; Meurers, 2000, Chapter 10.4.1.4.

¹⁸Tilman Höhle suggested using the same rule for the combination of particle and verb as for the verbal complex in his 1976 dissertation. The chapter of his dissertation that deals with this issue was published as Höhle (1982). Höhle deals mainly with morphological problems. The syntactic properties of the particle verb constructions are not explored in detail.

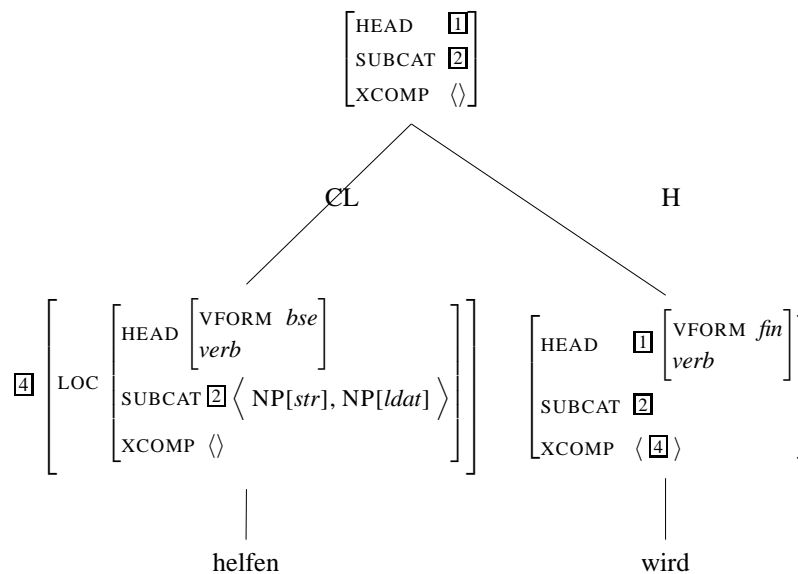

Figure 4: Analysis of the Verbal Complex: *daß er dem Mann helfen wird*.

4.1 Fronting

Particles can be fronted, although this is often denied. Different claims about non-frontability have been made by Bierwisch (1963, p. 103), Kiss (1994, p. 100), Olsen (1997, p. 307), Zifonun (1999, p. 227), Eisenberg (1999, p. 306), and others. Due to space limitations I cannot discuss all claims here, but see Müller (2002). Usually fronted particles are contrasted, or a focus (on the complete verb) is established.

- (19) (a) **Los** ging es schon in dieser Woche.¹⁹
 PART went it already in this week
 'It already started this week.'
- (b) **Vor** hat er das jedenfalls.²⁰
 PART (before) has he this in.any.case
 'He plans (to do) that anyway.'
- (c) **Auf** fällt, daß ...²¹
 PART falls that
 'It is noticed that ...'

Müller (1999, Ch. 19.1.2) and Müller (2002) provided further fronting examples from corpora with particles that are homophonous to nouns, adjectives, and adverbs.

A non-finite particle verb cannot be fronted without its particle:²²

- (20) * **Schlafen** wird Karl ein.
 sleep will Karl PART
 Intended: 'Karl will fall asleep.'

¹⁹taz, 10.11.1995, p. 4

²⁰taz, 07.15.1999, p. 19

²¹Duden (1991, p. 62)

²²See for instance Höhle (1982, p. 101), Haftka (1981, p. 721), Olszok (1983, p. 127), and Lötscher (1985, p. 212) for similar examples.

The examples of particle fronting in (19) are parallel to examples where verbs or adjectives are fronted.

- (21) (a) Erzählen wird er seiner Tochter ein Märchen.²³
 tell will he his daughter a fairytale
 ‘He will tell his daughter a fairytale.’
 (b) Treu will Karl seiner Frau sein.
 faithful wants Karl his wife be
 ‘Karl wants to be faithful to his wife.’

In (21a) only the verb *erzählen* is fronted. The complements of this verb remain to the right of the finite verb in the so-called *Mittelfeld*. (21b) is an example of a fronted adjective. The example in (20) is parallel to the examples in (22).

- (22) (a) *Müssen wird er ihr ein Märchen erzählen.
 must will he her a fairytale tell
 Intended: ‘He will have to tell her a fairytale.’
 (b) *Sein will Karl seiner Frau treu.
 be wants Karl his wife faithful
 Intended: ‘Karl wants to be faithful to his wife.’

The generalization about these ungrammatical examples is that if parts of the predicate complex are fronted (alone or with adjuncts or complements), all parts of the predicate complex that are governed by fronted heads have to be fronted together with this head. So in (22a) *müssen* governs *erzählen*. If *müssen* is fronted *erzählen* has to move as well. If particles are analyzed as parts of the predicate complex, the ungrammaticality of (20) is explained.

4.2 The Right Sentence Bracket

It can be observed that particles behave similarly to verbs and adjectives in respect to serialization. They are located at the right periphery of a clause in the so-called right sentence bracket.²⁴ To see this, consider the control verb *vorschlagen* (‘suggest’), which can appear discontinuously.

- (23) (a) Karl schlägt der Frau vor in die Stadt zu gehen.
 Karl beats the woman PART into the town to go
 ‘Karl suggests to the woman to go to town.’
 (b) *Karl schlägt vor der Frau, in die Stadt zu gehen.

If serializations of the particle in adverb positions were possible, orders like those in (23b) should also be possible, since they are possible with adverbs, as (24) shows.

- (24) (a) Karl überredete die Frau gestern, in die Stadt zu gehen.
 Karl persuaded the woman yesterday into the town to go
 ‘Karl persuaded the woman to go to town yesterday.’
 (b) Karl überredete gestern die Frau, in die Stadt zu gehen.

²³Haftka (1981, p. 720–721). For more data see Müller (1999, Chapter 18).

²⁴Cf. (Drach, 1937, p. 55)

But this is not the case. (23b) is totally out since it would be an instance of multiple extraposition with an NP and a VP. NP extraposition as such is rather marked, but together with an extraposed infinitive the sentence becomes unacceptable. This suggests that particles occupy the same position as that occupied by non-finite verbs in sentences that do not contain a finite particle verb, like (25).

- (25) Er hat den Hund geschlagen.
 he has the dog beaten
 ‘He beat the dog.’

The particle marks the right sentence boundary. If the particle + verb combination are licensed by the same grammar rule as the auxiliary + verb combination in (25), the facts can be explained easily.

4.3 Separation of Particle and Verb in Head-Final Contexts

The examples in (26) and (30) seem to contradict the assumption that particle and verb form a predicate complex since the particle and the verb are not adjacent parts of the right sentence bracket in these examples.

- (26) Andrew Halsey ist auf dem Weg von Kalifornien nach Australien weit ab
 Andrew Halsey is on the way from California to Australia far off
 vom Kurs gekommen.²⁵
 from.the course come.
 ‘On the way from California to Australia Andrew Halsey strayed way off course.’

In (26) the meaning of the particle *ab* is further specified by a *von*-PP. Usually such further specifications can be provided by PPs with a preposition that corresponds to the particle, as in (27).

- (27) (a) Er legte die Folie auf den Projektor auf.
 he laid the transparency on the projector on
 ‘He placed the transparency on the overhead projector.’
 (b) Er warf die Briefe in den Briefkasten ein.
 he threw the letters in the letterbox in
 ‘He posted the letters.’

There are no particle verbs in German that have a *von* as particle. *ab* is used instead (Fourquet, 1974; Stiebels, 1996, p. 86, p. 94). If the particle *ab* is further specified, a *von* PP is used, as in (26).

Phrases of the form *weit ab* + *von*-PP can also appear as normal adjuncts as in (28) and it could be argued that (26) is an instance of the same construction.

- (28) Weitab vom Zentrum [...] eröffnete Alfred Bauer [...] am 6. Juni das Filmfest
 im alten Titania-Palast aus den 20er-Jahren.²⁶
 far .off of.the center opened Alfred Bauer at 6. June the film.festival in.the old
 Titania-Palace from the twenties.

‘Far from the center Alfred Bauer opened the film festival in the old 20’s Titania Palace on 6 June.’

²⁵taz, 04.10.1999, p. 20

²⁶taz berlin, 05.02.2000, p. 25

In (28) this phrase specifies the location of *eröffnen*. That the *ab* in (26) is really a particle and not an adjunct as in (28) is clear if we compare (26) with (29) where the *ab* + *von*-PP has been omitted. The sentence without *ab* has a totally different meaning:

- (29) Er ist auf dem Weg von Kalifornien nach Australien gekommen.
 he is on the way from California to Australia come
 ‘He came on the way from California to Australia.’

This shows that *ab* in (26) really is a part of a particle verb. The particle is further specified by a *von*-PP and therefore the *ab* is not adjacent to *gekommen*. However, the phrase *weit ab vom Kurs* is adjacent to *gekommen*. Sentences like (26) are unproblematic for analyses that assume that particle and verb are combined in syntax.

In (30) the particles are separated from their verb by a locative PP.

- (30) Ich weiß, daß die Sonne auf im Osten und unter im Westen
 I know that the sun PART(up) in.the east and PART(under) in.the west
 geht.²⁷
 goes
 ‘I know that the sun rises in the east and sets in the west.’

But as Lüdeling (2001, p. 51) notes, these examples are caused by focus split. That it is possible to intrapose certain parts of the predicate complex was also shown by the examples with adjectives in Müller (1999, Chapter 18.4.3). Lüdeling (2001, p. 50) showed that intraposition of the resultative predicates in resultative constructions is also possible. Again, a syntactic analysis of particle verbs that treats the particles as part of the predicate complex can explain the data.

Grewendorf (1990, p. 99) gives the German example in (31) where the particle verb *anfang* (‘to start’) appears discontinuously in a head-final context.

- (31) Heut im Traum sah ich sie wieder
 Und von allen Bergen ging solches
 Grüßen zu mir nieder
 Daß ich an zu weinen fing²⁸
 that I PART to cry caught
 ‘I saw her in my dream again today, and the mountains gave me such a welcoming feeling that I started to cry.’

It is tempting to count this example as an intentional breach of the rules since it is quoted from a poem, but such orders are attested in some German dialects. Werner (1994, p. 356) gives the examples in (32), attested in the northwest of Sonneberg/Thuringia.

- (32) (a) a ... hot aa ze schimpfm gfang
 he has PART to get.angry caught
 ‘He started to get angry.’
 (b) die ham ... auf zu arwettn ghört
 they have PART to work heard
 ‘They stopped working.’
 (c) ham sa groud aa mit assn gfang
 have they just PART with eat caught
 ‘Did they just start to eat?’

²⁷Lüdeling (2001, p. 51).

²⁸Joseph von Eichendorff, *Erinnerung, Gedichte [Ausgabe 1841]*, Eichendorff-W. Vol. 1, p. 77.

In (32) the phase verbs *angefangen* ('started') and *aufgehört* ('stopped') appear discontinuously. The embedded verb intervenes between the base verb of the matrix verb and the particle that belongs to the matrix verb. Furthermore, Werner (1994) discusses sentences like those in (33) in which a particle verb is embedded under a modal (33a) or under a perfect auxiliary and a modal (33b,c). The particle verb appears discontinuously with the particle at the left periphery of the verbal complex.²⁹

- (33) (a) so ham sich die Leut oumüßploug³⁰
 so have self the people PART.must.struggle
 'people had to struggle so much'
- (b) Wos da sich ölles aahotmüßhör!³¹
 what there self all PART.has.must.hear
 'All these things he had to listen to!'
- (c) wall e in Brander vollstn ümhotwöllstimm³²
 because he the Brander completely PART.has.want.to.tune
 'because he wanted to change Brander's mind completely'

Werner (1994, p. 355) argues that these orderings follow the pattern in (34).

- (34) (a) weil er in die Stadt / fort geht.
 because he in the town away goes
 'because he goes to town / away.'
- (b) weil er in die Stadt / fort hat müssen gehen.³³
 because he in the town away has must go
 'because he had to go to town / away.'

Particle verbs developed historically from adverb+verb combinations. The canonical position of adverbs is in front of the verbal complex. Most of these adverbs changed their meaning and the combinations became lexicalized. In the East Franconian/Thuringian dialect, the canonical order with respect to modals is preserved.

The fact that particle and verb may be separated even in head-final contexts both in Standard German and especially in German dialects is explained easily by a syntactic analysis.

In the following subsections, I provide the basic lexical entries for non-transparent particle verbs, and I discuss lexical rules that allow templates to be derived for some prototypical particle verbs that are the result of productive particle verb combinations. The combination of particle and verb in syntax is licensed by the head cluster schema that was introduced in section 3.

²⁹Similar constructions can be found in Dutch, where particle and verb also may be serialized discontinuously. Koster (1975, p. 126) provides the following example:

- (i) omdat Carol hem op kon bellen
 because Carol him PART can call
 'because Carol can call him.'

³⁰Werner (1994, p. 349).

³¹Werner (1994, p. 355).

³²Werner (1994, p. 355).

³³This is the order of the elements in the verbal complex in Thuringian. For Standard German it is *hat gehen müssen*.

4.4 Lexical Entries for Particle Verbs

(35) shows the lexical entry for the non-transparent particle verb *vorhaben* ('to plan').

(35) (*vor*) *hab-* ('to plan', non-transparent particle verb):

CAT	<table style="border-collapse: collapse;"> <tr> <td style="padding: 2px 5px;">HEAD</td> <td style="padding: 2px 5px;"><i>verb</i></td> </tr> <tr> <td style="padding: 2px 5px;">SUBCAT</td> <td style="padding: 2px 5px;"> \langle NP[<i>str</i>]_[1], NP[<i>str</i>]_[2] \rangle </td> </tr> <tr> <td style="padding: 2px 5px;">VCOMP</td> <td style="padding: 2px 5px;"> \langle PART[<i>vor</i>] \rangle </td> </tr> </table>	HEAD	<i>verb</i>	SUBCAT	\langle NP[<i>str</i>] _[1] , NP[<i>str</i>] _[2] \rangle	VCOMP	\langle PART[<i>vor</i>] \rangle
HEAD	<i>verb</i>						
SUBCAT	\langle NP[<i>str</i>] _[1] , NP[<i>str</i>] _[2] \rangle						
VCOMP	\langle PART[<i>vor</i>] \rangle						
CONT	<table style="border-collapse: collapse;"> <tr> <td style="padding: 2px 5px;">ARG1</td> <td style="padding: 2px 5px;">[1]</td> </tr> <tr> <td style="padding: 2px 5px;">ARG2</td> <td style="padding: 2px 5px;">[2]</td> </tr> <tr> <td style="padding: 2px 5px;"></td> <td style="padding: 2px 5px;"><i>vorhaben</i></td> </tr> </table>	ARG1	[1]	ARG2	[2]		<i>vorhaben</i>
ARG1	[1]						
ARG2	[2]						
	<i>vorhaben</i>						

The semantic contribution of the particle verb is not computed compositionally from the meaning of the verb and the particle when they are combined in the sentence, but is represented as the CONT value of the stem. The form of the particle that has to be combined with the (inflected) stem is fully specified in the lexical entry as the VCOMP element.

I follow Olsen (1999, p. 238) and McIntyre (2001b, p. 44) in assuming that particles like *vor* are not prepositions, but are related to prepositions by lexical redundancy rules. The particle is selected like other complements that form a complex with their head via VCOMP. Figure 5 on the following page shows the analysis for (36), where the verb is in final position.

(36) weil er das vorhat.
because he that PART(before).has
'because he plans to do this'

Particle and verb are combined in a head cluster structure and then the accusative object and the subject are combined with the head in further projections licensed by the head complement schema.

See Müller (2000, p. 222) for the analysis of verb initial sentences.

Since particles are selected via VCOMP, why they can be fronted is explained. The extraction of particles is parallel to known cases of partial verb phrase fronting. It is not necessary to assume that extractions like the one in (37) are extractions out of words, as it would be if we assumed that *festzustehen* ('to be certain') is a word a part of which is fronted.

(37) *Fest* scheint auf jeden Fall *zu stehen*, daß ...³⁴
PART seems on any case to stand that
'In any case, it seems to be certain that ...'

Examples like (20) on page 12 are excluded since *wird* selects a verb with an empty VCOMP list. The form of *schlafen* in this sentence contains a description of the particle in their VCOMP list and therefore cannot function as a filler in a nonlocal dependency (see (Pollard & Sag, 1994, Chapter 4) for a treatment of nonlocal dependencies in HPSG).

After having shown how non-transparent particle verb combinations can be analyzed, I now turn to transparent particle verbs that follow a productive pattern and

³⁴Reis (1976, p. 68) discusses this sentence in the context of the raising verb *scheinen*, but she explicitly mentions the fact that a particle is fronted.

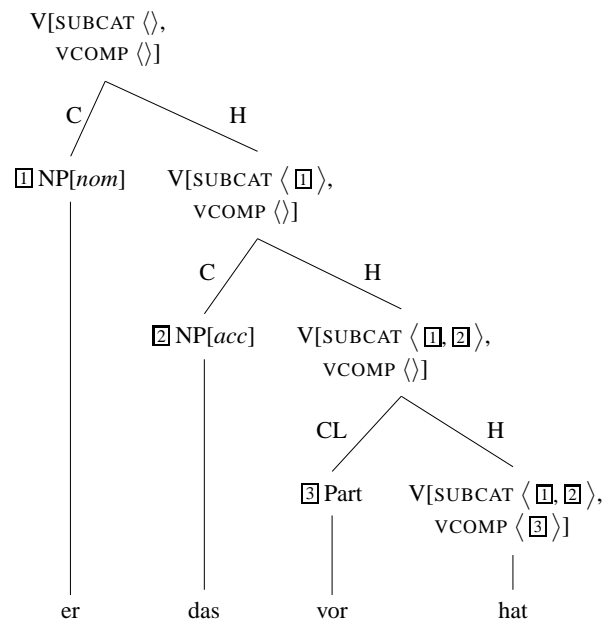

Figure 5: Analysis of *weil er das vorhat*.

can be analyzed compositionally. In what follows, I give some example analyses of transparent particle verbs that are representative for certain classes of particle verb combinations.

(38) shows examples where the particle is an aspectual marker. The particle does not change the argument structure of the verb. (38c) shows that it is impossible to have an additional NP complement that is not selected by the base verb. (38d–e) show that transitive verbs cannot be combined with the particle *los* if the object is expressed.

- (38) (a) Er lacht.
he laughs
- (b) Er lacht los.
he laughs PART
'He starts to laugh.'
- (c) * Er lacht sie los.
he laughs her PART
- (d) * Er liest das Buch los.
he reads the book PART
Intended: 'He starts to read the book.'
- (e) Er liest los.
he reads PART
'He starts to read.'

The particle *an₅* behaves differently. As the examples in (10) on page 7 show, *an₅* licenses an additional argument. The base verb must be intransitive and agentive (Stiebels & Wunderlich, 1994, p.950). This suggests that the particle is responsible for the argument structure of the complex verb. *an₅* adds an argument, but *los* does

not. Both particles can combine with intransitive verbs only. Furthermore, the particle selects the semantic class of the base verb. It is not adequate to analyze the particle as the head of the particle verb, as was suggested by Trost (1991, p. 438), since the particle is embedded under the verb in the predicate complex as was argued above. I therefore suggest treating particles like *los* and *an* as lexical adjuncts. Since they are adjuncts, they can impose their selectional restrictions on the head they combine with and can modify the meaning of their head. Since they are analyzed as lexically introduced dependents, they can contribute to the argument structure of the lexical object. This contribution is done by argument composition, a technique that was demonstrated in section 3 where I introduced the analysis of verbal complexes. In the version of HPSG that was developed by Pollard & Sag (1994), adjuncts select the head they modify via the MOD feature. Since MOD has a *synsem* object as its value, both syntactic and semantic properties of the modified head can be selected. On the other hand, syntactic properties of particle verbs suggest treating the particle as an element of the verbal complex (see section 4.1 and 4.2). I unify these two insights and analyze the particles in (10) and (38) as subcategorized modifiers. The lexical rule in (39) takes a verb with the empty list as VCOMP value as input and produces a new lexical item that is subcategorized for a particle.³⁵

(39) Lexical Rule for Productive Particle Verb Combinations:

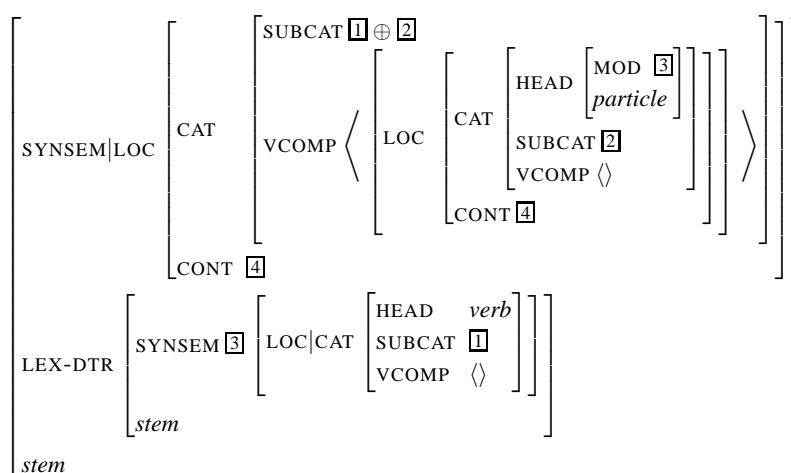

The rule applies to all verbs with an empty VCOMP value. The output of the rule is a verb that selects a particle. Whether the resulting verb is actually used in an analysis depends on the presence of a particle that can be combined with this verb. The valence requirements of the output verb are determined by the particle: The SUBCAT value of the particle is attracted by the output verb. The rule licenses verbal stems that select particles that modify the base verb semantically. This is indicated by the structure sharing of the MOD value of the particle and the SYNSEM value of the input verb (3).³⁶

Note that I do not claim that all particle verb combinations follow this pattern. Stiebels & Wunderlich (1994, p. 930) identified five different types of particle verb

³⁵Note that the lexical rules in this article are abbreviations. The values of features that are neither mentioned in the LEX-DTR nor in the mother are assumed to be structure shared, i.e., to be identical.

³⁶The rule in (39) is in a certain way similar to the Adjunct Introduction Lexical Rule that van Noord & Bouma (1994) use: Like in van Noord and Bouma's rule, an adjunct is introduced into a valence feature list.

constructions where the particle is related to a preposition. Only one type is dealt with here. The other cases can be dealt with with similar lexical rules.

Particles like those in (10) and (38) have the form of adjuncts. They select their head via MOD. The entry for *los* is shown in (40).

(40) *los* (aspectual marker):

$$\left[\begin{array}{l} \text{CAT} \\ \text{CONT} \end{array} \left[\begin{array}{l} \text{HEAD} \\ \text{SUBCAT} \\ \text{VCOMP} \\ \text{ARG} \end{array} \left[\begin{array}{l} \text{MOD } V[\text{SUBCAT} \langle \text{NP}[\textit{str}] \rangle], \text{CONT } \boxed{1} \\ \textit{particle} \\ \langle \rangle \\ \langle \rangle \\ \boxed{1} \\ \textit{begin} \end{array} \right] \right] \right]$$

This particle modifies an intransitive verb (SUBCAT = $\langle \rangle$) and encapsulates the semantics of this verb ($\boxed{1}$) under the relation it contributes (*begin*). When lexical items that are licensed by the lexical rule in (39) are combined with the particle, they take the semantic contribution from the particle. This is ensured by the structure sharing $\boxed{4}$ in (39).

Figure 6 on the next page shows the representation of valence information in an analysis of *losfahren* (‘start to drive’) where the particle *los* is combined with a lexical item that is licensed by the particle verb lexical rule on the basis of the lexical entry for the intransitive version of *fahr-* (‘to drive’) in (41).

(41) *fahr-* (‘to drive’):

$$\left[\begin{array}{l} \text{CAT} \\ \text{CONT} \end{array} \left[\begin{array}{l} \text{HEAD} \\ \text{SUBCAT} \\ \text{VCOMP} \\ \text{AGENT} \end{array} \left[\begin{array}{l} \textit{verb} \\ \langle \text{NP}[\textit{str}] \boxed{1} \rangle \\ \langle \rangle \\ \boxed{1} \\ \textit{fahren} \end{array} \right] \right] \right]$$

The particle verb lexical rule applies to the stem entry of *fahr-* and licenses a lexical item that contains a particle in VCOMP. The licensed lexical item is a stem that has to be inflected before it can be combined with the particle. Since inflection has not been dealt with yet, inflection is not represented in figure 6. The details of inflection will be explained in section 5.1. The concatenation of the SUBCAT value of the input verb ($\boxed{1}$) and the SUBCAT value of the selected particle ($\boxed{2}$) is identical to the SUBCAT value of the output of the lexical rule. This technique of argument attraction is the same we have seen in section 3 where we discussed the analysis of the verbal complex. In the next step the verb is combined with the particle *los* in a head cluster structure (Schema 1 on page 11). Since *los* has no element in SUBCAT, $\boxed{2}$ is the empty list. Therefore the SUBCAT value of the verb *fahren* that is subcategorized for a particle is a list that contains an element that is identical to the subject of the simplex verb *fahren*. Since the SUBCAT value of the mother is identical to the SUBCAT value of the head daughter in head cluster structures, the SUBCAT value of the complete particle verb is also $\boxed{1} \oplus \boxed{2}$ and hence the SUBCAT value of *losfahren* is identical to the SUBCAT list of *fahren*, hence *losfahren* is an intransitive verb.

Since the particle verb lexical rule identifies the MOD value of the particle with the SYNSEM value of the base verb ($\boxed{4}$ in figure 6), the particle *los* can access properties of the base verb it attaches to and can hence also impose constraints on the length of the

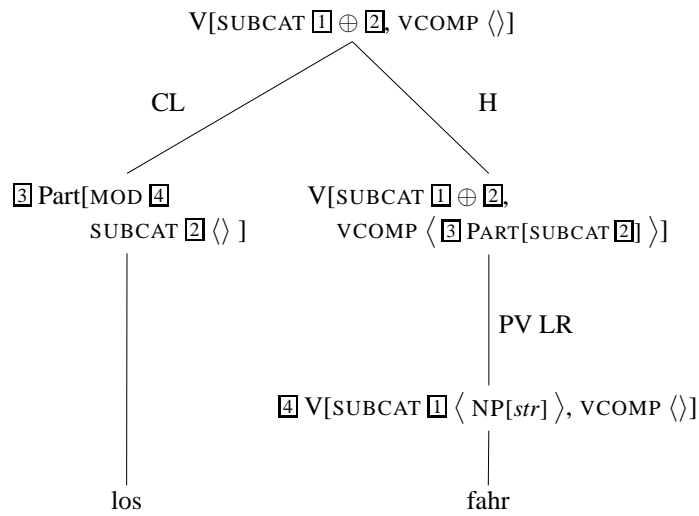

Figure 6: Combination of *los* and *fahren* (valence information)

SUBCAT list of the base verb. It can therefore be ensured that *los* attaches to intransitive verbs only.

Now consider the representation of semantic information in the analysis of *los-fahren*, which is shown in figure 7. The particle verb lexical rule applies to *fahr*- and

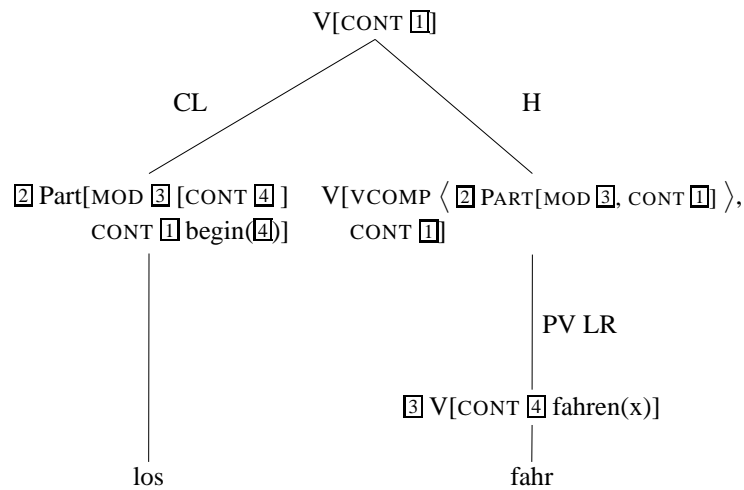

Figure 7: Combination of *los* and *fahren* (semantic information)

licenses a lexical item that selects a particle the MOD value of which is identical to the input of the rule (3). Therefore this particle can access the semantic information contributed by the base verb. The output of the lexical rule has a CONT value that is identical to the CONT value of the particle (1). The actual value is not constrained by the feature description of the lexical entry that selects the particle. The only thing one knows at this point is that there will be a particle and that it will contribute some mean-

ing. In the next step the verb that selects for the particle is combined with the particle. This combination is licensed by the head cluster schema which was given on page 11. The semantics principle ensures that the meaning contribution of the head in the head cluster structure is identical to the meaning contribution of the mother, hence $\boxed{1}$ is the CONT value of the complete particle verb. The actual value of $\boxed{1}$ is determined by the particle. In the case of *los* the particle contributes the *begin* relation. The argument of the *begin* relation is the semantic contribution of the base verb: *fahren*(*x*). The particle can access the meaning contribution of the base verb since the MOD value of the particle is identified with the SYNSEM value of the base verb ($\boxed{3}$). In the lexical entry (40) for *los* it is specified that the CONT value of the modified element is the argument of the *begin* relation. The full semantic contribution of the particle in figure 7 is therefore *begin*(*fahren*(*x*)) where *x* is linked to the agent of *fahren*. Since this meaning contribution is identified with the meaning of the verb selecting for the particle and also with the meaning of the complete particle verb, the meaning of the complete verb is also *begin*(*fahren*(*x*)).

Now consider what happens if we combine the particle verb entry for *fahren* with *an*. The lexical entry for the particle *an*₅ differs from the one for *los* in licensing an additional argument. The appropriate entry is given in (42):

$$(42) \text{ } an_5 \text{ (direction):}$$

$$\left[\begin{array}{l} \text{CAT} \\ \text{CONT} \end{array} \left[\begin{array}{l} \text{HEAD} \left[\begin{array}{l} \text{MOD } V[\text{SUBCAT} \langle \text{NP}[\textit{str}] \rangle, \text{CONT } \boxed{1}] \\ \textit{particle} \end{array} \right] \\ \text{SUBCAT} \langle \text{NP}[\textit{str}] \boxed{2} \rangle \\ \text{VCOMP} \langle \rangle \\ \text{ARG1 } \boxed{1} \\ \text{ARG2 } \boxed{2} \\ \textit{directed-towards} \end{array} \right] \right]$$

The additional argument—an NP bearing structural case—is represented as an element in the SUBJ value. This element is linked to an argument of the *directed-towards* relation ($\boxed{2}$). The other argument of this relation is identified with the content provided by the base verb.

Figure 8 on the next page shows the valence representations in the analysis of the combination of the particle *an*₅ with *fahren*. This figure is parallel to figure 6 on the preceding page which showed the analysis of *losfahren*. The only difference is that *an*₅ has an element in SUBCAT. Therefore $\boxed{1} \oplus \boxed{2}$ is a list that contains two NPs with structural case, i.e., *anfahren* is a transitive verb.

The composition of the meaning of *anfahren* is completely analogous to the meaning composition for *losfahren* which was shown in figure 7 on the page before.

After having shown how productive particle verb combinations with adjunct-like particles can be accounted for, I now turn to the morphology of particle verbs and show that the analysis presented above does not lead to paradoxes.

5 Morphology

There are two basic approaches to inflectional and derivational morphology. The first is called ‘Item-and-Arrangement (IA) approach’, ‘Morpheme-based approach’, or ‘Word Syntax approach’. It is assumed that words consist of morphemes that are form meaning pairs. Such morphemes are combined in a way that is similar to what is known

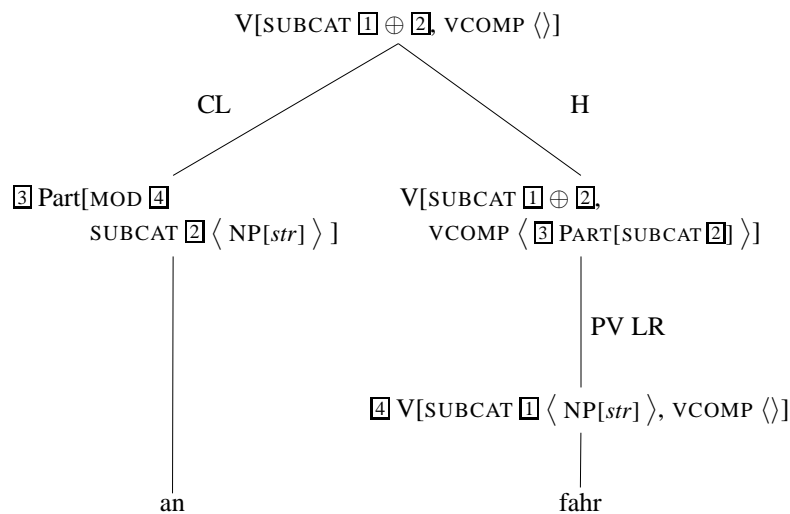

Figure 8: Combination of *an* and *fahren* (valence information)

from syntax. The alternative proposal is called ‘Item-and-Process (IP) approach’. Here it is assumed that stems are related to other stems or to words by realizational rules.³⁷ Affixes are not elements of the lexicon. The phonological material that is contributed by an affix in the Item-and-Arrangement model is introduced in the process that derives a form from a given stem or word. For a comparison of the two approaches see Hockett (1954) and Anderson (1988).

As an example consider the inflected form *fragt* (‘asks’) which consists of the stem *frag-* and the ending *-t*. In a morpheme-based approach both the stem and the ending are morphemes and it is assumed that both bear meaning. The word *fragt* has the structure *frag + t*. In a Item-and-Process approach there is no lexical entry for *-t*. Instead the form *fragt* is licensed by a process that relates the stem to the fully inflected word (*frag* ⇒ *fragt*). The information that *t* is an appropriate ending for the present tense is contained in the definition of the relation that relates the stem to the word.

In the HPSG paradigm both Item-and-Arrangement and Item-and-Process analyses have been developed: Trost (1991, 1993), Krieger & Nerbonne (1993), Krieger (1994), van Eynde (1994, Chapter 4), and Lebeth (1994) suggest an affix-based approach and Pollard & Sag (1987, Chapter 8.2), Orgun (1996), Riehemann (1998), Ackerman & Webelhuth (1998), Kathol (1999), and Koenig (1999)³⁸ use lexical rules that relate stems to other stems or words.

One advantage of the IP view is that one does not have to stipulate zero morphemes for cases of zero inflection or conversion. Another advantage is that the stipulation of subtractive morphemes is not necessary. Hockett (1954, p. 224) discusses cases from Chinese and French where a shorter form is regarded as derived from a longer more basic one (*bon* vs. *bonne* is the French example). A morpheme-based analysis would have to stipulate an abstract entity that has some meaning, but no phonological form. If it is combined with some other element, phonological material of this element is deleted. In the IP view, on the other hand, there is just a mapping from *bonne* to *bon*

³⁷See Becker (1993) for a proposal that does not assume stems, but relates words to words.

³⁸For non-HPSG-based approaches see for instance (Dowty, 1979, p. 304; Stump, 1991; Aronoff, 1994).

and the fact that something is deleted is encoded in this mapping.

A morpheme-based analysis of German nominalizations can be found for instance in Bierwisch (1989). Bierwisch uses an abstract morpheme /Ablaut/. If a stem is combined with this morpheme the result is an object with an appropriately modified phonology.

In order to avoid zero morphemes and subtractive morphemes, I suggest a lexical rule-based analysis in what follows.

5.1 Inflection

The lexical rule in (43) is used to derive inflected lexical items from items that are listed in the lexicon or that have been derived by other lexical rules that map uninflected lexical items to other uninflected lexical items. So it can be used to derive *fährst* from various forms of *fahr-* ('to drive'). One entry for *fahr-* is the one that is listed. Another one is derived by the rule for productive particle verb combinations (see (39) on page 19), and can be used in sentences like *er fährt los* ('he starts to drive').

(43) Lexical rule for the 2nd person singular, present:

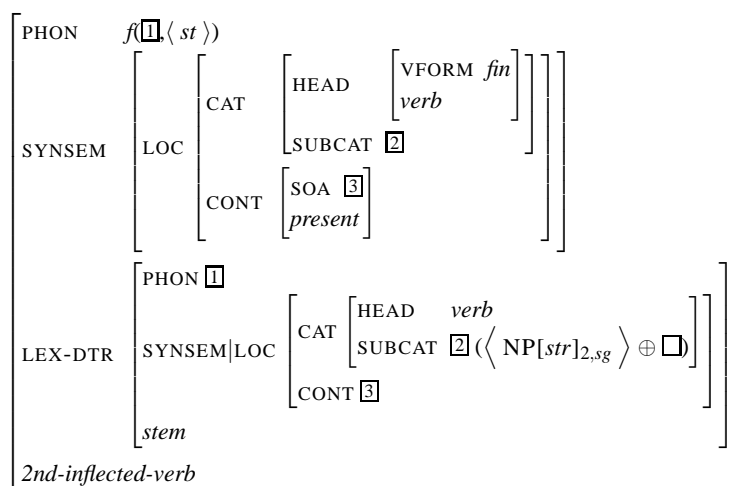

This lexical rule produces a finite form from the stem that may be basic or derived. The function f combines the phonological representation of the rule input ($\boxed{1}$) with the ending *-st*. The function may add, delete, or change phonological material if necessary. For instance, the combination of *red-* and *-st* is *redest* ('talk'). The VFORM value is instantiated appropriately and since I assume that subjects of finite verbs are represented on the SUBCAT list, the uninflected stem is required to have a NP[*str*] as its first element in the SUBCAT list. This element is constrained to be second person singular. The meaning of the input ($\boxed{3}$) is embedded under the *present* relation.³⁹ The agreement information is directly represented at the subject. The rule in (43) is a subtype of a general lexical rule for the formation of finite verbs. For other forms of the inflectional paradigm there will be other subtypes that add other phonological information to the stem and that enforce different agreement features on the subject. For subjectless verbs

³⁹This representation of tense is a simplification. It can be replaced by a more appropriate analysis. See Sag & Wasow (1999) for a representation using Minimal Recursion Semantics (MRS).

and verbs with clausal subjects there is a version of the rule above that adds a third person singular ending to the phonology value of the stem without imposing agreement constraints on a dependent.

The two lexemes for *fahr-* that were mentioned above cannot be used in syntax since they are of the wrong type: they are not subtypes of *word*, only the output of lexical rules for inflection is.

If the rule in (43) is applied to the listed entry for the simplex verb *fahr-* in (41), one gets (44).

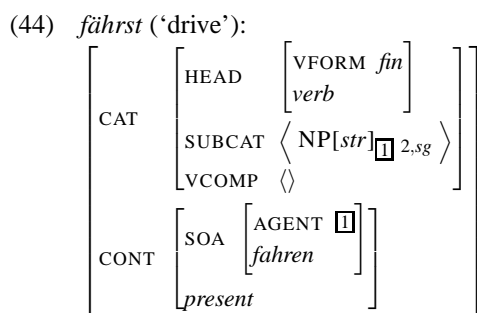

Figure 9 shows what happens if the inflection lexical rule is applied to the output of the particle verb lexical rule. In the output of the particle verb lexical rule the CONT

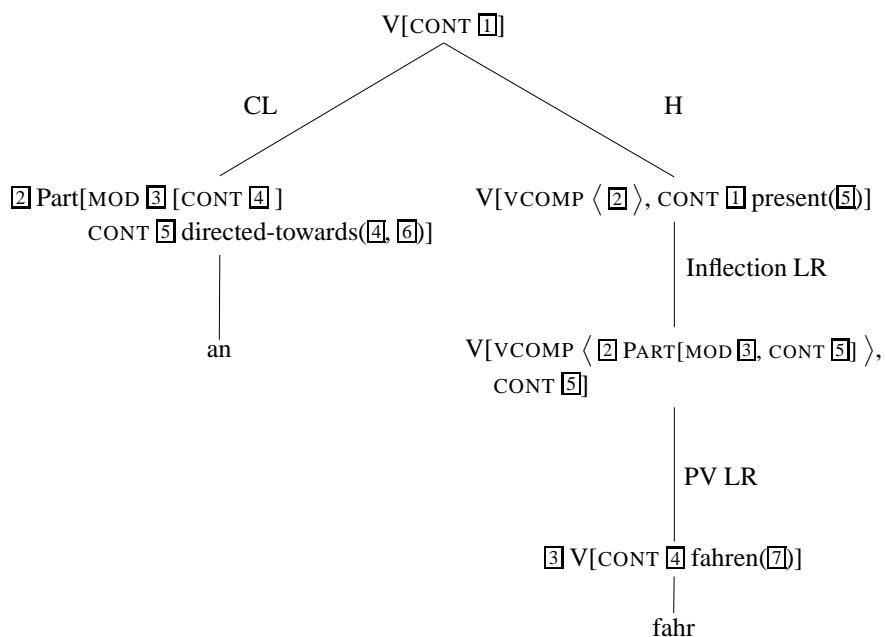

Figure 9: Inflection of *fahr-* and combination with *an*

value is structure shared with the CONT value of the particle (5). This CONT value is embedded under the *present* relation in the output of the inflection lexical rule. When a particle is combined with the inflected form of *fahr-*, the actual semantic contribution gets instantiated. In the case of *an* the semantic contribution is *directed-towards*(4, 6)

where [6] is linked to the NP that is licensed by *an*₅ and [4] is the semantic contribution of the base verb.

The participle inflection is dependent on the stress pattern of the verb: If the first syllable is stressed the participle is formed with *ge-* (45a), if it is not stressed the *ge-* is omitted (45b).

- (45) (a) gerédet ('talked'), gearbeitet ('worked')
(b) diskutiert ('discussed'), krakéelt ('made a racket')

The distribution of *ge-* is the same for simplex and particle verbs. Therefore it is sufficient to assume that the lexical rule that licenses the participle form is sensitive to the phonological form of the base verb. The phonological contribution of the particle that will be combined with the verb is totally irrelevant for the distribution of *ge-*. Since the form of the particle does not matter as far as the phonology of the participle inflection is concerned it is unproblematic that the particle and the base verb are discontinuous in verb initial sentences.

Geilfuss-Wolfgang (1998) develops an OT analysis for the distribution of *ge-*, including the distribution in particle verbs. He tries to capture the data on a purely phonological basis. In order to achieve this he has to stipulate four constraints, one specific to *ge-* and one specific to particle verbs. Such stipulations are not necessary in the approach suggested in this paper.

5.2 Derivation

In the following subsections I will show how *Ge-* *-e-*nominalizations and *-bar-*derivations can be analyzed without getting the bracketing paradoxes that were discussed in section 2.

5.2.1 *Ge-* *-e-*nominalizations

There are various ways in which the arguments of a verb can be realized after nominalization has been applied. The subject or object of the verb can be realized as a *von*-PP (46a), as a postnominal genitive NP (46b), or it may be left implicit (46c).

- (46) (a) das Angebrülle von Norbert⁴⁰
the PART (at).screaming from Norbert
'Norbert's screaming at somebody'
(b) das Rumgeheule der FDP⁴¹
the PART (around).shouting of.the FDP
'the FDP's whining'
(c) das Herumgerenne⁴²
the PART (around).running
'the running around'

Rather than giving a detailed account of the various ways in which arguments can be realized, I will consider the case where all arguments are suppressed. The main purpose of this section is not to provide all the details of argument realizations in nominal

⁴⁰taz, 15.10.1993, p. 16

⁴¹taz, 07.01.1998, p. 3

⁴²taz, 01.02.1999, p. 16

environments, but rather to show how *Ge-* *-e*-nominalizations can be accounted for without a bracketing paradox.

The lexical rule in (47) can be used to derive nominalizations like the one in (46c).

(47) Lexical rule for *Ge-* *-e*-nominalizations:

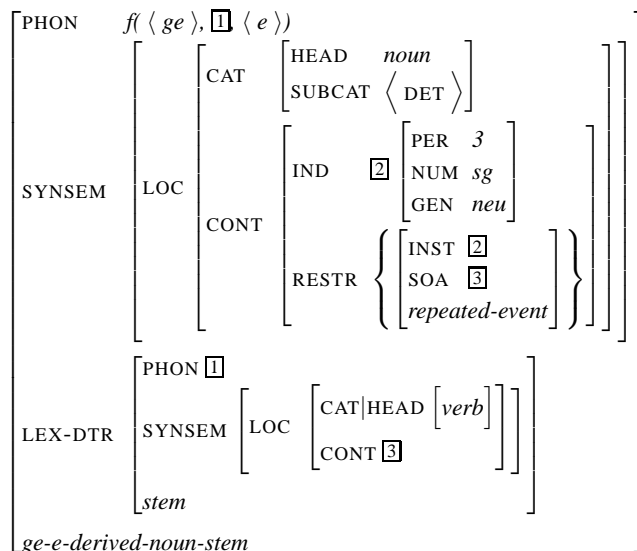

Again, f is a function that combines the PHON value of the input with *Ge-* *-e*. The e is optional if it follows the unstressed syllables *-er*, *-el*, *-en* as, for instance, in *Rumgeballer*. The result of the rule application is a noun stem. This stem has to be inflected before it can be used in syntax. Zero-inflection gives nominative, dative, and accusative; appending an s results in genitive.

The rule in (47) applies to all verbs. The valence properties of the nominalized verb are ignored since this lexical rule licenses only the bare noun with a determiner without any complements that could be inherited from the verb. Following Pollard & Sag (1994, Chapter 1) and Demske (2001), I assume that the noun selects a determiner, i.e., I assume an NP analysis rather than a DP analysis, but the rule in (47) could be easily changed. For a DP analysis in HPSG see Abb (1994). A special variant of a DP analysis can be found in Netter (1994) and Netter (1998).

Since nouns derived by *Ge-* *-e*-nominalization are neuter, the lexical rule licenses a noun that has a referential index that has the GENDER value *neu*. *Ge-* *-e*-nominalizations do not have plural forms (Bierwisch, 1989, p. 34). Since the number is also specified in the output of the lexical rule, plural inflectional affixes cannot be combined with stems licensed by (47). The referential index ($\boxed{2}$) is identical with the value of the INST feature of the *repeated-event* relation.

Consider first *Gerenne* as it can be derived from the verb *renn-* without a particle. The entry for *renn-* is analogous to the one for *fahr-* in (41). It is given in (48).

(48) *renn-* ('run'):

$$\left[\begin{array}{l} \text{CAT} \left[\begin{array}{l} \text{HEAD } \textit{verb} \\ \text{SUBCAT } \langle \text{NP}[\textit{str}] \boxed{1} \rangle \\ \text{VCOMP } \langle \rangle \end{array} \right] \\ \text{CONT} \left[\begin{array}{l} \text{AGENT } \boxed{1} \\ \textit{rennen} \end{array} \right] \end{array} \right]$$

If this lexical entry is fed into (47), the result is (49).

(49) *Gerenne-* ('repeated running'):

$$\left[\begin{array}{l} \text{CAT} \left[\begin{array}{l} \text{HEAD } \textit{noun} \\ \text{SUBCAT } \langle \text{DET} \rangle \end{array} \right] \\ \text{CONT} \left[\begin{array}{l} \text{IND } \boxed{2} \left[\begin{array}{l} \text{PER } 3 \\ \text{NUM } \textit{sg} \\ \text{GEN } \textit{neu} \end{array} \right] \\ \text{RESTR } \left\{ \begin{array}{l} \text{INST } \boxed{2} \\ \text{SOA } \left[\begin{array}{l} \text{AGENT } \boxed{} \\ \textit{rennen} \end{array} \right] \\ \textit{repeated-event} \end{array} \right\} \end{array} \right] \end{array} \right]$$

The agent of *rennen* is not linked to any element in the valence representation and hence the value of the AGENT feature in (49) is visualized as an empty box.

Next I want to discuss the analysis of *Herumgerenne*. Like *los*, the particle *herum* attaches to intransitive verbs only, as (50) shows:

- (50) (a) Karl rennt / hüpft herum.
Karl runs jumps around
- (b) Karl liest (in dem Buch) herum.
Karl reads in the book around
- (c) *Karl liest das Buch herum.
Karl reads the book around

There are several meanings of *herum*. The one that is of interest here adds a component to the meaning of the base verb that the action is aimless.

(51) *herum* ('around'):

$$\left[\begin{array}{l} \text{CAT} \left[\begin{array}{l} \text{HEAD } \left[\text{MOD } \text{V}[\text{SUBCAT } \langle \text{NP}[\textit{str}] \rangle], \text{CONT } \boxed{1} \right] \\ \textit{particle} \end{array} \right] \\ \text{SUBCAT } \langle \rangle \\ \text{VCOMP } \langle \rangle \\ \text{CONT} \left[\begin{array}{l} \text{SOA } \boxed{1} \\ \textit{aimless} \end{array} \right] \end{array} \right]$$

The analysis of *Herumgerenne* is shown in figure 10 on the next page.

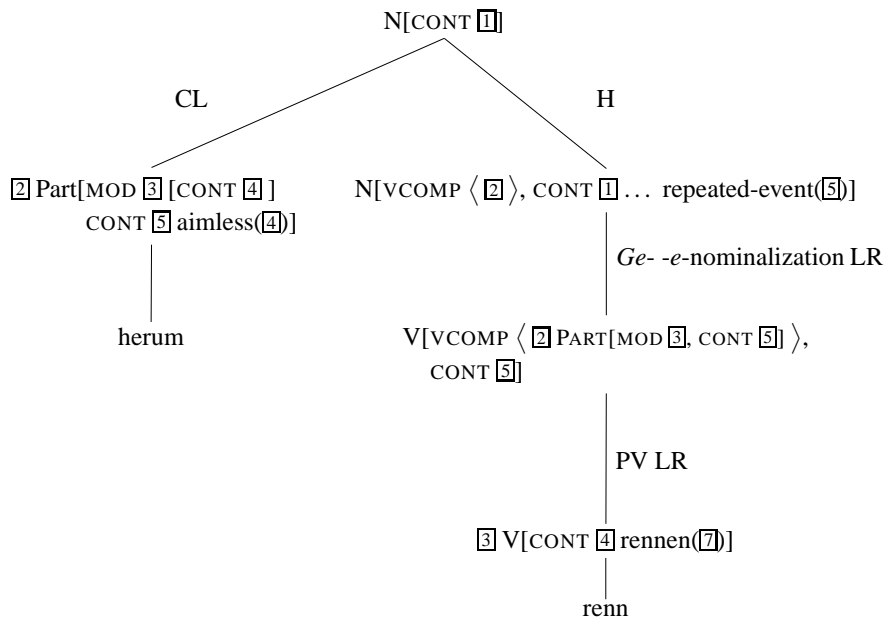

Figure 10: Analysis of *Herumgerenne*

To derive *Herumgerenne* we first have to apply the lexical rule (39) for productive particle verb combinations to the entry for *renn-* that is listed in the lexicon. The result is a lexical item that selects a particle via *VCOMP* (2). The meaning contribution of this particle (5) is identified with the meaning of the lexical item that is licensed by the particle verb lexical rule. The nominalization lexical rule applies to this item and encapsulates the semantic contribution under the *repeated-event* relation. In the next step the noun is combined with the particle. Since the noun is the head in a head cluster structure its meaning contribution (1) is identical to the meaning contribution of the mother. The meaning contribution of the particle is now known. Via its *MOD* value the particle can access the semantic contribution of the base verb (4) and can embed this under the *aimless* relation. The result is *aimless(rennen(7))*. Since this semantic contribution is embedded under *repeated-event* by the nominalization rule, we get *repeated-event(aimless(rennen(7)))* and hence the correct semantic representation.

Having dealt with inflection and with *Ge- -e-nominalization*, I can now explain the most difficult part of the analysis: the *-bar-*derivation.

5.2.2 Adjective Derivation

The *-bar-*derivation with particle verbs is the most difficult part, since both syntactic constraints and proper scope relations are relevant for this derivation.

Riehemann (1998) assumes a schema for *-bar*-derivation that is similar to the following:

(52) Lexical rule for the derivation of adjectives with *-bar*:

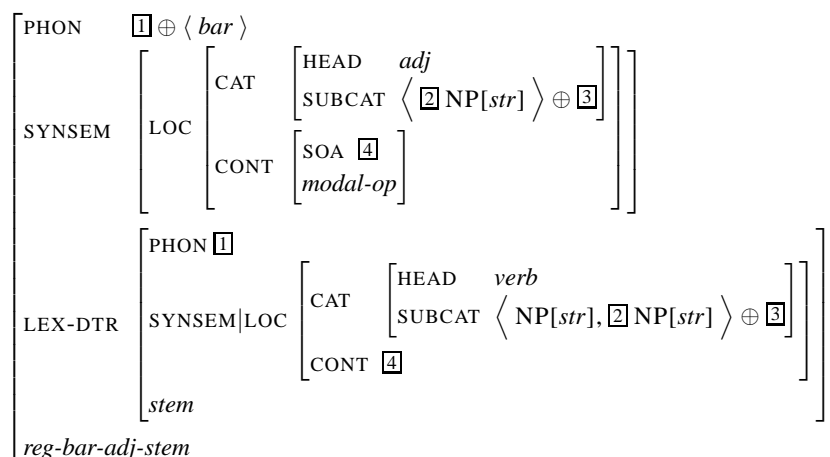

This lexical rule applies to a transitive verb and promotes the accusative object to the subject of the adjective. This process is similar to passivization. The rule in (52) is a subtype of a type that specifies the subject demotion that is common to all passive-like constructions.

The result of this lexical rule is a stem that has to go through an inflection lexical rule in order to become a word that can take part in syntactic combinations. An inflectional rule that does not add phonological material produces a lexical item that can be used predicatively in copula constructions. Other rules that add phonological material license the attributive forms that are inflected and can be used prenominally.⁴³

To start with a simple example, I show what happens with a transitive verb without particle. The feature description in (54) corresponds to the transitive use of *fahren* as in (53).

(53) Sie fährt ein Auto mit geringem Spritverbrauch.
she drives a car with low gas.consumption

(54) *fahr-* ('to drive'):

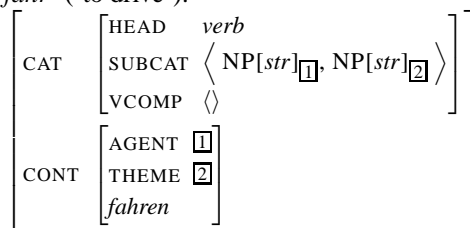

⁴³See also Koenig (1999, p. 118) for a similar proposal for the interaction of inflection and derivation.

The rule in (52) promotes the object of *fahren* to the subject of the adjective. The subject of *fahren* is suppressed.

(55) *fahrbar-* ('possible to drive'):

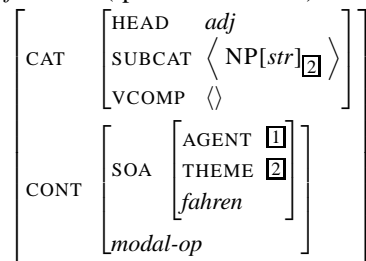

This entry can be used to analyze phrases like (56).

(56) *der fahrbare* *Untersatz*⁴⁴
the possible.to.drive underneath.put
'wheels' / 'the car'

In what follows I demonstrate what happens if the *-bar*-derivation lexical rule is applied to the lexical item that is licensed by the particle verb lexical rule. I split the discussion in two parts, first discussing valence properties and then turning to the semantics.

Figure 11 shows the application of the particle verb lexical rule. The result of the

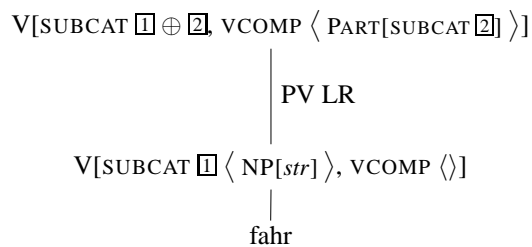

Figure 11: Application of the particle verb lexical rule to *fahr-*

rule application is a lexical item that has an underspecified SUBCAT value. The actual value is constrained by the particle once the particle is combined with its head.

The *-bar*-derivation lexical rule requires its input to have an object NP with structural case. Since the output of the particle verb lexical rule is compatible with this requirement, the *-bar*-derivation lexical rule can apply to it. This is shown in figure 12 on the next page. The SUBCAT value of the input to the *-bar*-derivation is constrained to be a list that starts with two NP[*str*] ($\langle \text{NP}[\mathit{str}], \boxed{1} \text{NP}[\mathit{str}] \rangle \oplus \boxed{4}$). Since the SUBCAT value of the input to the *-bar*-derivation in figure 12 is the concatenation of the SUBCAT value of the simplex verb and the SUBCAT value of the particle in VCOMP, only particles that have an NP[*str*] at the first position of their SUBCAT list may combine with the result of the *-bar*-derivation.

Figure 13 on the following page shows the combination of *ans* and *fahrbar*. The particle has an NP[*str*] in its SUBCAT list ($\boxed{2}$). Therefore the concatenation of $\boxed{1}$ and $\boxed{2}$

⁴⁴taz, 03.20.1999, p. 30

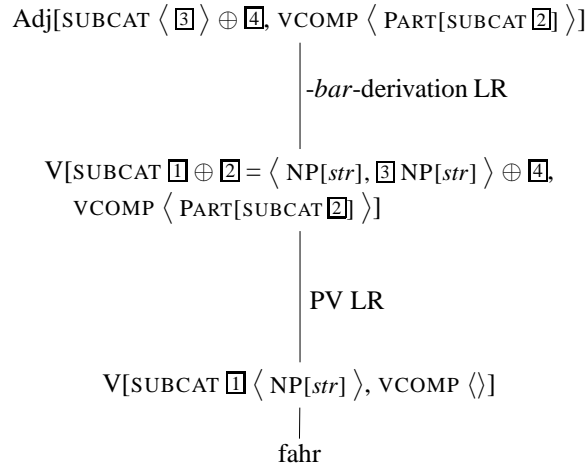

Figure 12: Application of the *-bar-derivation* lexical rule to *fahr-* with particle in VCOMP

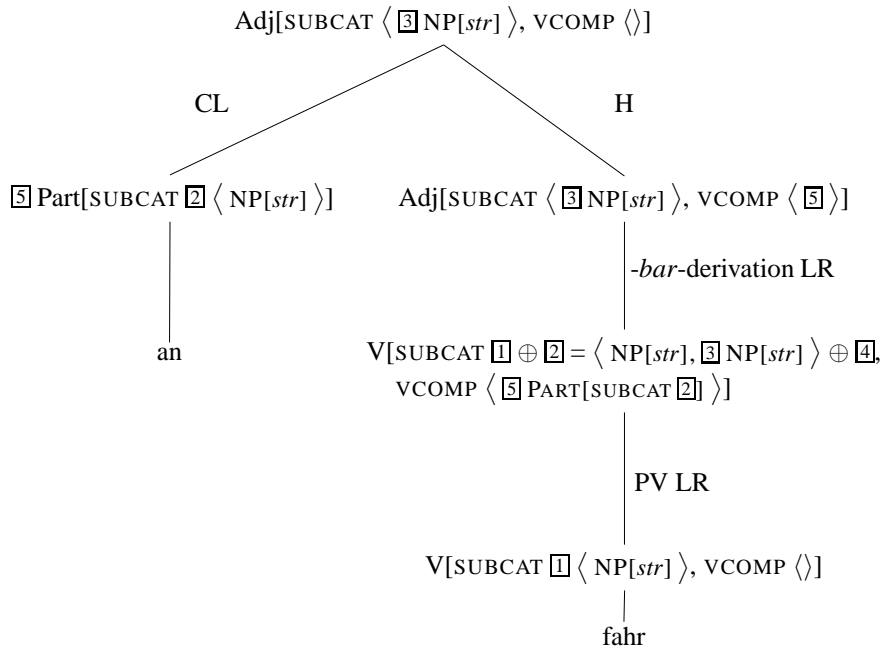

Figure 13: Combination of *an*₅ and *fahrbar* (valence information)

is a list that contains two NP[*str*]. The second NP[*str*] is identified with the element [3] which is raised to subject by the *-bar*-derivation lexical rule. Since there are just two NPs in the concatenation of [1] and [2], [4] is the empty list. Therefore the adjective *anfahrbar* has as the only element on its SUBCAT list the element that was introduced by the particle. Hence, the NP licensed by the particle is the subject of the adjective.

The interesting thing is that this analysis not only derives (57a), it also blocks (57b).

- (57) (a) die anfahrbaren Geschäfte
the PART.drivable shops
‘the shops that can be accessed by vehicle’
- (b) * die losfahrbaren Geschäfte
the PART.drivable shops
Corresponding to: ‘*the shops that can be started to drive’
- (c) ? die losfahrbaren Autos
the off.drivable cars
‘the cars that can be driven off’

The reason is that *los* does not introduce arguments. Since *los* only combines with intransitive verbs, the result of such a combination is again an intransitive verb. Although there is a form for *fahrbare*, it cannot be combined with *los* since the constraint imposed by the *-bar*-derivation lexical rule ($[1] \oplus [2] = \langle \text{NP}[\textit{str}], [3] \text{NP}[\textit{str}] \rangle \oplus [4]$) would be violated: $[1] \oplus [2]$ would contain just one element.

Note that (57c) has a marginal resultative reading for *losfahrbar*, with the resultative predicate *los* (‘off’). A context would be ten cars that are stuck in the snow and some of them can be freed by driving. This form of *losfahrbar* is also derived with the lexical rule (52), but it is derived from an entry for *fahr* that is the result of the resultative predicate lexical rule (see Müller (2000, p. 224)), and not from a lexical item that is licensed by the particle verb lexical rule. The lexical item with the resultative meaning cannot be used in an analysis of (57b), since the selectional restrictions of the resultative predicate *los* block the combination with *Geschäfte*.

Now consider the representation of semantic information in the analysis, which is shown in figure 14 on the next page. The particle verb lexical rule introduces a particle into the VCOMP list that selects the input representation via MOD ([3]). In the output of the lexical rule the CONT value of the output ([5]) is structure shared with the CONT value of the particle in VCOMP. The *-bar*-derivation lexical rule embeds this CONT value under *modal-op*. At this point no particle is present and therefore the actual value of [5] is not constrained. In the next step the particle is combined with *fahrbar*. The particle has the form of an adjunct. Its MOD value ([3]) is identified with the stem *fahr-* since this is specified so in the VCOMP value ([2]). Therefore the particle *an₅* can access the semantic contribution of the base verb *fahr-* and can integrate it into the semantic contribution of the particle. The result is *directed-towards*([4], [6]), where [4] stands for *fahren*([7]), i.e., we get *directed-towards*(*fahren*([7]), [6]). [6] and [7] are linked to the object and subject of *anfahren*, respectively.

Only after the combination of *an₅* and *fahrbar* it is clear what the value of [5] is. This value is an argument of the *modal-op* relation that was contributed by the *-bar*-derivation. Since *fahrbar* is the head of *anfahrbar*, the meaning of *anfahrbar* is identical to the meaning of *fahrbar* ([1]).

Elements that are derived from particle verbs can undergo further morphological processes:

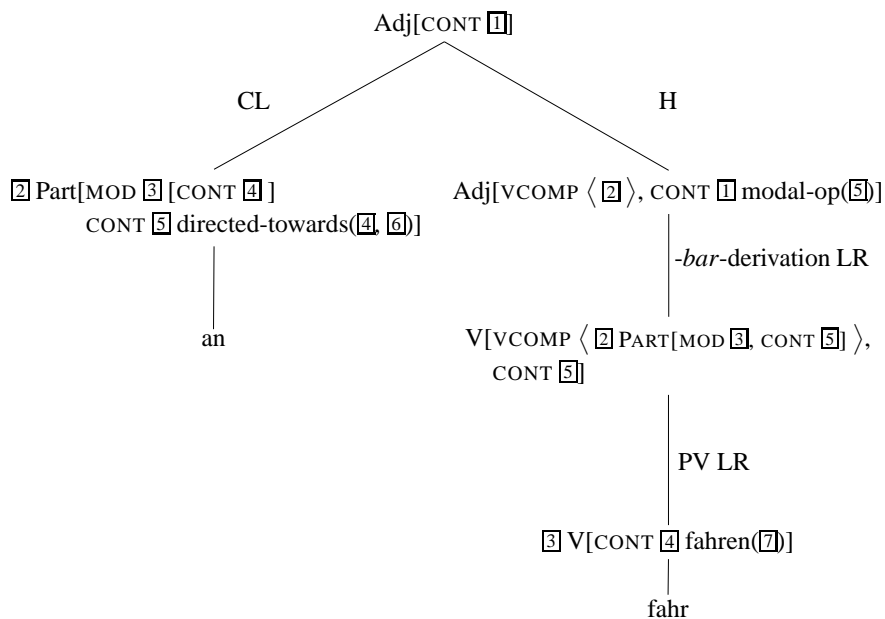

Figure 14: Combination of *an*₅ and *fahrbar* (semantic information)

- (58) (a) unannehmbar
unacceptable
- (b) das Pseudo-Herumgerede⁴⁵
the pseudo.babble

In (58a) *annehmbar* is prefixed with *un-* and in (58b) *Herumgerede* is combined with *Pseudo-*. Therefore it is necessary that the schema that combines the particle with the derived adjective or noun applies in the morphology component. The result is then the basis for the combination with elements like *un-* or *Pseudo-*.

6 Alternatives

In this section I discuss alternative proposals for the analysis of particle verbs. The first two deal explicitly with alleged bracketing paradoxes: The account suggested by Stiebels & Wunderlich (1994) uses Williams' (1981) notion of lexical relatedness and will be discussed in section 6.1. The second analysis was suggested by Stump (1991) and deals with morphosemantic mismatches in general (section 6.2). In section 6.3, I discuss the assumption of discontinuous lexical entries and in section 6.4 a discontinuous morphology as was suggested by Crysmann (1999) for Fox. Finally I will discuss Ackerman and Webelhuth's approach (1998) to particle verbs in section 6.5.

6.1 Rebracketing and Lexical Relatedness

⁴⁵Stiebels (1996, p. 40)

Stiebels & Wunderlich (1994, p. 935) and Stiebels (1996, Chapter 3.2.1) assume the structure in (59) for nominalizations like *Einführung* ('introduction').⁴⁶

(59) [ein [[führ]_V ung]_N]

They assume a notion of lexical relatedness that is similar to the one that was proposed by Williams (1981):

(60) *Lexical relatedness:*

A compound of the structure [P [α V β]_X], where X is a noun or adjective formed from a verb (with α, β as possible derivation affixes), may be interpreted as if α, β were applied to the respective verb [P V]. α and β may be (phonologically) empty.

As they note, this principle violates strict compositionality: They assume that *Führung* ('leadership'), *Gabe* ('gift') and *sehbar* ('watchable')⁴⁷ are parts of the words *Einführung* ('introduction'), *Abgabe* ('delivery'), and *absehbar* ('conceivable').

Stiebels and Wunderlich argue that such a postponed interpretation is needed for other cases of compounds too, since—according to them—*Aufsteher* ('riser') is ungrammatical and *Frühaufer* ('early.riser') is grammatical.

-er-nominalizations are used to refer to a certain discourse referent in a situation. Since *to get up* is not a property that discriminates between people, the noun *Aufsteher* ('up-getter', 'riser') as such is strange. Lüdeling (2001, p. 101) provides a context where the property of getting up discriminates between people and therefore can be used without further specification: The situation is a hospital where a certain group of patients is allowed to get up during the day while the others have to stay in bed. In this situation it is possible to refer to a member of the first group as *Aufsteher* ('person who gets up') and to a member of the second group as *Liegenbleiber* ('person who does not get up'). This shows that *Aufsteher* is not ungrammatical and therefore such examples do not count as independent evidence for a postponed interpretation in Stiebels and Wunderlich's sense.

On page 939 they discuss the data in (61):

- (61) (a) *bieten* ≈ *Gebot* ('offer')
 (b) *verbieten* ≈ *Verbot* ('forbid/ban')
 (c) *anbieten* ≈ *Angebot* ('offer')
 (d) *aufbieten* ≈ *Aufgebot* ('exert/exercion')

verbieten is a prefix verb and *anbieten* and *aufbieten* are particle verbs. The root noun related to *bieten* is *Bot*, which was subject to a prosodically triggered *ge*-prefixation in West Germanic. The prefixed root noun *Verbot* is listed and therefore the *ge*-prefixation does not apply. The nominalizations of particle verbs are formed with *Gebot*. Stiebels and Wunderlich conclude from this that *Angebot* and *Aufgebot* are compounds that are formed from *Gebot* and a preposition. However, the data is also compatible with the analysis presented in the previous section: The *ge*-prefixation applies to a stem that contains a representation of the particle in its valence lists. No lexical relatedness is needed.

⁴⁶For a general discussion of Stiebels and Wunderlich's account see also McIntyre (2001c). In the following section I will focus on their arguments regarding lexical relatedness.

⁴⁷*sehbar* is often discussed as an example for blocking, i. e., it is claimed that the word *sehbar* does not exist. However, only the sense 'visible' is not available.

That *leadership* has anything to do with *introduction* is highly implausible and any analysis that does not have to make such assumptions should be preferred over Stiebels and Wunderlich's. Furthermore, in their approach, not just the interpretation has to get postponed, but the evaluation of other constraints as well. Stiebels and Wunderlich do not have a solution to the problem of non-existent bases (see section 2.3): To derive *Ausbreitung* ('spreading') they have to assume **Breitung* as part of the analysis. Apart from this, it is not clear when the passive like suppression of the subject should apply in *-bar*-derivations. In their view, the *-bar*-derivation applies to an intransitive verb and the particle is combined with the result later. Only then the additional argument that is introduced by the particle is available. As was discussed in the data section, *-bar*-derivation productively applies only to transitive verbs.

6.2 Paradigm Functions

Stump (1991) suggests so-called paradigm functions that relate stems to stems or stems to words (roots to roots and roots to words in his terminology). These functions may be defined in a way that allows inflectional or derivational material to attach to a head contained in a more complex structure. With such a definition he can account for Pe-setsky's *unhappier* puzzle (1985): In general, the comparative suffix joins with short adjectives and does not attach to trisyllables, so a bracketing [[un-happy] er] is not possible since *unhappy* is trisyllabic. Because of the shortness constraint, [un [happi-er]] is the only available structure, but semantically one needs the first structure. For this comparative formation, Stump defines paradigm functions that attach the comparative ending to the head inside [un-happy]. As was mentioned in footnote 2 on page 3, he also allows combinations of derivational material with heads in complex structures. On page 714 he remarks that in derivational paradigms in which the derived member belongs to a syntactic category distinct from that of the base member, the derived member generally fails to allow this kind of structure where the inflectional or derivational material attaches to the head. He remarks that nouns derived from particle verbs are exceptions (*hang on* → *hanger on*, *pass by* → *passer-by*). In the previous section, it was shown how similar German examples can be handled without violating Stump's generalization. For *-bar*-derivation one does not need [[an-fahr]-bar] and *Ge-* *-e*-nominalization can be handled without the *Ge-* *-e* attaching to the head inside [herun-renn]. The account that was presented in the previous section has another advantage over a imaginable application of Stump's proposal to German particle verbs: It can deal with particle verbs like *eindosen* ('to tin') that are not derived from base verbs. A verb **dosen* does not exist (see Section 2.3). In the approach presented in the last section, *eindosen* is derived from the noun *Dose* ('tin'). The result of the application of a lexical rule is a verbal stem that selects the particle *ein*. This stem has to be inflected. In an adaption of Stump's approach to German particle verbs, the inflectional material could not attach to a HEAD since the category of *eindosen* (V) differs from *Dose* (N) and therefore *eindosen* is headless (see Stump's definition of head on page 681). This means that an adaption of Stump's approach cannot provide a uniform treatment of inflection and derivation for all classes of particle verbs where the inflectional or derivational material attaches to the stem directly.

6.3 Discontinuous Lexical Entries

In a grammar that allows for discontinuous constituents it is tempting to assume that particle verbs are discontinuous lexical entries. This has, for instance, been suggested

by Wells (1947, p. 106) (see also McCawley (1982, p. 91)). Kathol (1995, p. 244–248) formalizes this idea using the constituent order domains that were introduced to the HPSG framework by Reape (1992, 1994, 1996). Kathol suggests the following lexical entry for the non-transparent particle verb *aufwachen* ('wake up'):

(62) *aufwachen* ('wake up', according to Kathol (1995, p. 246)):

$$\left[\begin{array}{l} \dots | \text{HEAD} \boxed{1} [\textit{verb}] \\ \dots | \text{VCOMP} \langle \rangle \\ \text{DOM} \left\langle \left[\begin{array}{l} \langle \textit{wachen} \rangle \\ \dots | \text{HEAD} \boxed{1} [\textit{verb}] \\ \dots | \text{VCOMP} \langle \boxed{2} \rangle \end{array} \right] \right\rangle \circ \left\langle \left[\begin{array}{l} \langle \textit{auf} \rangle \\ \text{SYNSEM} \boxed{2} \left[\dots | \text{HEAD} \left[\begin{array}{l} \text{FLIP} - \\ \textit{sepref} \end{array} \right] \right] \right] \right\rangle \end{array} \right]$$

This lexical entry represents syntactic structure in the lexicon. The DOM value is identical to the DOM value that would result from a combination of particle and verb in syntax. \circ stands for the combination of two lists. Elements of the combined list can appear between elements of the other list as long as the relative order of elements of the same list is preserved. In the case of (62) this means that either *auf* precedes *wachen* or *wachen* precedes *auf*. Kathol's approach has the advantage that a feature that ensures that the base verb selects the right particle, i.e., *auf* instead of *vor* or something else, is not necessary. A similar analysis was suggested for idioms by Nunberg, Sag & Wasow (1994, p. 513). Idiom parts can be listed in the unordered domain list of a lexical entry with the correct representation of the non-compositional semantics. Both approaches are problematic since they cannot explain why particles and idiom parts can be fronted. Kathol distinguishes between compositional and non-compositional particle verbs and assumes that the compositional ones are licensed by his verb complex schema and non-compositional ones are listed in the form of lexical entries like (62).

As has been shown in Müller (2002), transparent and non-transparent particle verbs allow for the fronting of the particle (see also section 4.1). I therefore suggest that all particle verbs are represented in the same way and that fronting is restricted by general conditions for fronting and not by different lexical representations for different classes of particle verbs.

For German it is usually assumed that verb second is analyzed as extraction, i.e., as a nonlocal dependency. Nonlocal dependencies are analyzed by percolation mechanisms in HPSG (Pollard & Sag, 1987, 1994). Lexical entries like (62) represent an object that would be the result of a syntactic combination licensed by the predicate complex schema. An extraction of material out of this lexical entry is not possible. The only way to use lexical representations like (62) and nevertheless allow for particles to be fronted is to totally revise the analysis of nonlocal dependencies. Mechanisms for liberation of domain elements that can explain all data that have been discussed so far would have to be devised. As yet no such analysis exists.

A further disadvantage of Kathol's proposal is that the fact that particle verbs form a predicate complex is not represented in their lexical entries. The VCOMP value of *aufwachen* in (62) is the empty list. It is not obvious how the formation of resultative constructions with particle verbs like those in (63) can be blocked.

- (63) # daß sich Karl müde herumliest.
 that self Karl tired PART (around).reads
 Intended: 'that Karl gets tired by reading aimlessly.'

In the analysis developed in this article the particle is selected via *VCOMP*. As is argued in Müller (2000, p. 224), the resultative construction lexical rules require an input with an empty *VCOMP* list. Since the *VCOMP* list of particle verbs contains the particle, it is correctly predicted that particle verbs cannot be input to a lexical rule that licenses resultative constructions. See also Müller (2000, p. 227) on this point.

6.4 Linearization-Based Morphology

Crysmann (1999) developed an account for morphosyntactic paradoxes in Fox that uses linearization domains for the representation of stems and inflectional and derivational material. With such an approach it is possible to combine Kathol's representation of particle verbs, which was discussed in section 6.3 with a morphology component that circumvents the paradoxes. The participle *aufgewacht* ('woken up') can be analyzed as the result of a lexical rule application to a lexical item that contains *auf* and *wach* in a list of morphological objects. The lexical rule adds the morphological objects *ge* and *t* to this list. Linearization rules ensure that the *ge* and *t* attach to the verbal stem.

It is interesting that such a solution is possible in the HPSG framework, but I have shown that the additional machinery that would be needed to guarantee the proper linearization of the inflectional and derivational material and the extra list for the representation of morphological material is not justified. Furthermore this proposal, of course, has the problems discussed in section 6.3 since it is based on Kathol's analysis.

6.5 Ackerman and Webelhuth (1998)

Ackerman & Webelhuth (1998) develop a theory of complex predicates that integrates assumptions from both LFG and HPSG. Ackerman and Webelhuth use a separate valence feature *PART*. The value of this feature is a list that contains a particle if the verb occurs in verb initial position and that is empty when the verb occurs in final position. Their lexical entry for *an+ruft* is shown in (64) in a notation that is adapted to the one that I used throughout the paper.

(64) (*an*) *ruft* according to
Ackerman and Webelhuth (1998, p. 334–335):

$$\left[\begin{array}{l} \text{PHON} \langle \textit{ruft} \rangle \vee \langle \textit{anruft} \rangle \\ \text{SYNSEM|LOC|CAT} \left[\begin{array}{l} \text{SUBCAT} \langle \text{NP}[\textit{str}], \text{NP}[\textit{str}] \rangle \\ \text{PART} \langle \text{PART}[\textit{an}] \rangle \vee \langle \rangle \end{array} \right] \end{array} \right]$$

The proper distribution of the particle in both the valence feature and the phonological representation is ensured by type constraints that rule out the cases with a phonological representation *anruft* + particle *an* and the phonological representation *ruft* without a particle. With the types computed, (64) is equivalent to (65) and (66). (65) is the entry that is needed for clauses with the finite verb in the left sentence bracket.

(65) (*an*) *ruft* verb initial version according to Ackerman and Webelhuth:

$$\left[\begin{array}{l} \text{PHON} \langle \textit{ruft} \rangle \\ \text{SYNSEM|LOC|CAT} \left[\begin{array}{l} \text{SUBCAT} \langle \text{NP}[\textit{str}], \text{NP}[\textit{str}] \rangle \\ \text{PART} \langle \text{PART}[\textit{an}] \rangle \end{array} \right] \\ \textit{partld-lci} \wedge \textit{second-lci} \end{array} \right]$$

For the verb final case Ackermann and Webelhuth do not select the particle via a valence feature, but have the phonological contribution of the particle integrated in the phonological representation of the lexical entry.

(66) *anruft* verb final version according to Ackerman and Webelhuth:

$$\left[\begin{array}{l} \text{PHON} \langle \textit{anruft} \rangle \\ \text{SYNSEM|LOC|CAT} \left[\begin{array}{l} \text{SUBCAT} \langle \text{NP}[\textit{str}], \text{NP}[\textit{str}] \rangle \\ \text{PART} \langle \rangle \end{array} \right] \\ \textit{compound-lci} \end{array} \right]$$

So, the disjunctive specification in (64) is equivalent to two separate lexical entries. The representation of particle verbs which I suggested in section 4 is free of disjunctions. One single lexical entry for each particle verb is sufficient. In chapter 10.2.2 of their book Ackerman and Webelhuth argued at length against theories that stipulate two lexical entries for particle verbs, whether related by lexical rules or not. Of course, two lexical rules that derive two lexical entries from one representation in a stem lexicon can be reformulated as one lexical rule producing a disjunctively specified output. That is what Ackerman and Webelhuth did. So, if their argument has any force at all, it is an argument against their own theory.

The lexical entry in (66) states that particle and verb constitute a single object that may not be separated. As should be clear from the discussion of the data in section 4.2, there are several problematic aspects of such an approach. Firstly, it cannot explain why the particle may appear separated from the verb, even in verb final sentences. Example (26)—repeated as (67) for convenience—shows that the particle (*ab* in this sentence) can appear non-adjacent to its base verb.

(67) Andrew Halsey ist auf dem Weg von Kalifornien nach Australien weit ab
 Andrew Halsey is on the way from California to Australia far off
 vom Kurs gekommen.⁴⁸
 from.the course come.

‘On the way from California to Australia Andrew Halsey strayed way off course.’

This example further shows that there are particles that have a syntactic life in that they can be modified. This fact is not accounted for by Ackerman and Webelhuth’s approach at all. Apart from that, they cannot explain the separation of verb and particle in Thuringian verbal complexes.

Secondly, consider the sentences in (68):

- (68) (a) *Schicht* hat von denen keiner *gearbeitet*.⁴⁹
 PART(shift) has of those nobody worked
 ‘None of them has worked shifts.’
- (b) *Dagegen* ist zu *halten*, daß [...] ⁵⁰
 this.against is to hold that
 ‘As an argument against this, it has to be said, that [...]’
- (c) *Fest* scheint auch zu *stehen*, daß ... ⁵¹
 PART(solid) seems also to stand that
 ‘It seems to be certain that ...’

⁴⁸taz, 04.10.1999, p. 20

⁴⁹Spiegel, 48/99, p. 305

⁵⁰In the main text of Heringer (1973, p. 93).

⁵¹In the main text of Engel (1977, p. 219).

In these sentences the particle is fronted and the base verb is non-finite. In Ackerman and Webelhuth's approach such non-finite particle verbs are analyzed as words. Therefore Ackerman and Webelhuth would have to assume extraction out of words to explain these sentences.

Ackerman and Webelhuth do not deal with resultative constructions in their book at all. But if they assume a lexical rule for resultative constructions, the impossibility of particle verbs to appear in resultative constructions would have to be enforced by the stipulation of the value of PART as the empty list in the lexical rule for resultative constructions. But this stipulation does not help in the case of verb last particle verbs, since the particle is not contained in the valence list of verb last verbs. The only way to block a resultative predicate lexical rule from applying is to stipulate that it does not apply to words of the type *compound-li*. This means that they have to stipulate two different reasons for why particle verbs cannot be input to resultative predicate lexical rules. The iteration of particles as in (69d) has to be excluded too and again there will be two different reasons why the iteration of particles is impossible.

- (69) (a) weil Maria lacht.
because Maria laughs
- (b) weil Maria loslacht.
because Maria PART.laugh
'because Maria starts to laugh'
- (c) weil Maria Karl anlacht.
because Maria Karl PART.laugh
'because Maria smiles at Karl.'
- (d) * weil Maria Karl anloslacht.
because Maria Karl PART.PART.laugh
Intended: 'because Maria starts to smile at Karl.'

(69b,c) show the combination of the particles *los* and *an* with the verb *lachen* as used in (69a). *los* attaches to intransitive verbs and forms an intransitive verb. *an* attaches to intransitive verbs and forms a transitive verb. In principle, it should be possible to combine an *an* with the intransitive verb *loslachen*, but this is excluded as (69d) shows. The reading that (69d) would have is not semantically implausible. That structural factors are responsible for the ungrammaticality of particle iteration is also shown by McIntyre's examples (2001c, p. 26) in (70).

- (70) (a) * herumangeben
around.show off
Intended: 'show off around'
- (b) herumprahlen
around.boast
'boast around'

The verbs *angeben* and *prahlen* are semantically similar. The reason for the ungrammaticality of (70a) is that *angeben* is a particle verb and hence cannot be combined with a further particle.

In the approach presented in this paper, the fact that particles cannot be iterated and that particles and resultative predicates are mutually exclusive follows from the fact that the productive rules add to the same valence list that has to be empty in the input of the rules (Müller, 2000, p. 225). Furthermore, it has to be remarked that with their

use of a separate valence feature for particles, Ackerman and Webelhuth do not capture the similarities between verbal complexes and particle verb combinations.

Ackerman & Webelhuth (1998, p. 333) assume the following morphological pattern for particle-verb compounding:⁵²

(71) Morphological pattern for particle-verb compounding according to Ackerman & Webelhuth (1998, p. 333):

$$\left[\begin{array}{l} \text{MS} \\ \text{MDTR} \\ \text{MDTR2} \end{array} \left[\begin{array}{l} \text{POS } \boxed{5} \\ \text{PHON } \boxed{3} + \boxed{4} \\ \text{INFL } \boxed{6} \end{array} \right] \right]$$

$$\left[\begin{array}{l} \text{MS} \\ \text{MS} \end{array} \left[\begin{array}{l} \text{POS } p \\ \text{PHON } \boxed{3} \\ \textit{part-word} \end{array} \right] \right]$$

$$\left[\begin{array}{l} \text{MS} \\ \text{MS} \end{array} \left[\begin{array}{l} \text{POS } \boxed{5} \\ \text{PHON } \boxed{4} \\ \text{INFL } \boxed{6} \\ \textit{simplex-word} \end{array} \right] \right]$$

They assume that a fully inflected particle verb like *anruft* is created by compounding the particle with the fully inflected word form *ruft* which bears the same inflectional features (INFL) as the resulting compound.

This approach cannot account for particle-verb combinations with non-existent base verbs like *eindosen* ('to tin') (see section 2.3). Since there is no verb **dosen*, it cannot be used for compounding in a schema like (71).

7 Summary

After the discussion of data in section 2, an account for particle verbs that treats particles as part of the predicate complex has been developed. The particle is selected by the same valence feature as other complements that form a complex with their head. The lexical rules that license particle verbs that follow a productive pattern do not combine two adjacent elements, but for every input entry they license another lexical item that has the potential to combine with a particle. Since matrix verb and particle do not form one single object, the matrix verb may appear in clause initial position separated from the embedded particle, or the matrix verb may appear clause finally and the particle adjacent to it or intraposed between other syntactic material of the clause.

I developed an approach to inflectional and derivational morphology that handles the data without powerful devices like rebracketing or discontinuous morphology. Inflection and derivation apply to stems directly, the particle is attached to fully inflected signs by an instance of the same grammar rule, either in morphology or in syntax.

⁵²I omitted their LME feature. POS stands for part of speech and INFL for inflection.

References

- Abb, Bernd. 1994. Die Generierung deutscher Nominalstrukturen. Hamburger Arbeitspapiere zur Sprachproduktion – V Arbeitspapier Nr. 18, Universität Hamburg, Fachbereich Informatik.
- Ackerman, Farrell & Webelhuth, Gert. 1998. *A Theory of Predicates*. CSLI Lecture Notes, No. 76, Stanford, California: CSLI Publications.
- Anderson, Stephen R. 1988. Morphological Theory. In Frederick J. Newmeyer (ed.), *Linguistics: The Cambridge Survey / Vol. I: Linguistic Theory: Foundations*, pages 146–191, Cambridge: Cambridge University Press.
- Aronoff, Mark. 1994. *Morphology by Itself. Stems and Inflectional Classes*. Linguistic Inquiry Monographs, No. 22, Cambridge, Massachusetts/London, England: The MIT Press.
- Becker, Thomas. 1993. Back-Formation, Cross-Formation, and ‘Bracketing Paradoxes’ in Paradigmatic Morphology. In Geert Booij & Jaap van Marle (eds.), *Yearbook of Morphology*, volume 6, pages 1–25, Dordrecht: Holland, Providence: U.S.A.: Foris Publications.
- Bierwisch, Manfred. 1963. *Grammatik des deutschen Verbs*. studia grammatica II, Berlin: Akademie Verlag.
- Bierwisch, Manfred. 1987. A Structural Paradox in Lexical Knowledge. In Elke van der Meer & J. Hoffmann (eds.), *Knowledge Aided Information Processing*, pages 141–172, Amsterdam: Elsevier Science Publisher B.V. (North-Holland).
- Bierwisch, Manfred. 1989. Event Nominalizations. In Wolfgang Motsch (ed.), *Wortstruktur und Satzstruktur*, Linguistische Studien, No. 194, pages 1–73, Berlin: Akademie Verlag.
- Bierwisch, Manfred. 1990. Verb Cluster Formation as a Morphological Process. In Geert E. Booij & Jaap van Merle (eds.), *Yearbook of Morphology*, volume 3, pages 173–199, Dordrecht: Holland, Providence: U.S.A.: Foris Publications.
- Bunt, Harry & van Horck, Arthur (eds.). 1996. *Discontinuous Constituency*. Natural Language Processing, No. 6, Berlin, New York: Mouton de Gruyter.
- Chung, Chan. 1993. Korean Auxiliary Verb Constructions Without VP Nodes. In Susumo Kuno, Ik-Hwan Lee, John Whitman, Joan Maling, Young-Se Kang & Young joo Kim (eds.), *Proceedings of the 1993 Workshop on Korean Linguistics*, Harvard Studies in Korean Linguistics, No. 5, pages 274–286, Cambridge, Massachusetts: Harvard University, Department of Linguistics.
- Crysmann, Berthold. 1999. Morphosyntactic Paradoxa in Fox. In Gosse Bouma, Erhard W. Hinrichs, Geert-Jan M. Kruijff & Richard T. Oehrle (eds.), *Constraints and Resources in Natural Language Syntax and Semantics*, Studies in Constraint-Based Lexicalism, No. 3, pages 41–61, Stanford: CSLI Publications.
- Demske, Ulrike. 2001. *Merkmale und Relationen. Diachrone Studien zur Nominalphrase des Deutschen*. Studia Linguistica Germanica, No. 56, Berlin, New York: Walter de Gruyter Verlag.
- Dowty, David R. 1979. *Word Meaning and Montague Grammar*. Synthese Language Library, No. 7, Dordrecht, Boston, London: D. Reidel Publishing Company.
- Drach, Erich. 1937. *Grundgedanken der deutschen Satzlehre*. Darmstadt: Wissenschaftliche Buchgesellschaft.
- Duden. 1991. *Die deutsche Rechtschreibung*, volume 1. Mannheim, Leipzig, Wien, Zürich: Dudenverlag.
- Eisenberg, Peter. 1999. *Grundriß der deutschen Grammatik*, volume 2. Der Satz. Stuttgart, Weimar: Verlag J. B. Metzler.

- Engel, Ulrich. 1977. *Syntax der deutschen Gegenwartssprache*, volume 22 of *Grundlagen der Germanistik*. Berlin: Erich Schmidt Verlag.
- Fleischer, Wolfgang & Barz, Irmhild. 1995. *Wortbildung der deutschen Gegenwartssprache*. Tübingen: Max Niemeyer Verlag, second edition.
- Fourquet, Jean. 1974. Die verbalen Zusammensetzungen des Neuhochdeutschen. Trennbare und untrennbare Partikeln. In Ulrich Engel & Paul Grebe (eds.), *Sprachsystem und Sprachgebrauch. Festschrift für Hogo Moser*, volume 33 of *Sprache der Gegenwart – Schriften des IdS Mannheim*, pages 98–111, Düsseldorf: Pädagogischer Verlag Schwann.
- Geilfuss-Wolfgang, Jochen. 1998. Über die optimale Position von *ge*. *Linguistische Berichte* 176, 581–588.
- Grewendorf, Günther. 1990. Verb-Bewegung und Negation im Deutschen. *Groninger Arbeiten zur Germanistischen Linguistik* 30, 57–125.
- Haftka, Brigitta. 1981. Reihenfolgebeziehungen im Satz (Topologie). In Karl Erich Heidolph, Walter Flämig & Walter Motsch (eds.), *Grundzüge einer deutschen Grammatik*, pages 702–764, Berlin – Hauptstadt der DDR: Akademie Verlag.
- Haider, Hubert. 1993. *Deutsche Syntax – generativ. Vorstudien zur Theorie einer projektiven Grammatik*. Tübinger Beiträge zur Linguistik, No. 325, Tübingen: Gunter Narr Verlag.
- Heringer, Hans-Jürgen. 1973. *Theorie der deutschen Syntax*. Linguistische Reihe, No. 1, München: Max Hueber Verlag, second edition.
- Hinrichs, Erhard W. & Nakazawa, Tsuneko. 1989. Subcategorization and VP Structure in German. In *Aspects of German VP Structure*, SfS-Report-01-93, Eberhard-Karls-Universität Tübingen.
- Hinrichs, Erhard W. & Nakazawa, Tsuneko. 1994. Linearizing AUXs in German Verbal Complexes. In Nerbonne et. al. (1994), pages 11–38.
- Hockett, Charles F. 1954. Two Models of Grammatical Description. *Word* 10, 210–234.
- Höhle, Tilman N. 1982. Über Komposition und Derivation: zur Konstituentenstruktur von Wortbildungsprodukten im Deutschen. *Zeitschrift für Sprachwissenschaft* 1, 76–112.
- Kathol, Andreas. 1995. *Linearization-Based German Syntax*. Ph.D.thesis, Ohio State University.
- Kathol, Andreas. 1998. Constituency and Linearization of Verbal Complexes. In Erhard W. Hinrichs, Andreas Kathol & Tsuneko Nakazawa (eds.), *Complex Predicates in Nonderivational Syntax*, volume 30 of *Syntax and Semantics*, pages 221–270, San Diego: Academic Press.
- Kathol, Andreas. 1999. Agreement and the Syntax-Morphology Interface in HPSG. In Robert D. Levine & Georgia M. Green (eds.), *Studies in Contemporary Phrase Structure Grammar*, pages 223–274, Cambridge: Cambridge University Press.
- Kiss, Tibor. 1994. Obligatory Coherence: The Structure of German Modal Verb Constructions. In Nerbonne et. al. (1994), pages 71–108.
- Kiss, Tibor. 1995. *Infinite Komplementation. Neue Studien zum deutschen Verbum infinitum*. Linguistische Arbeiten, No. 333, Tübingen: Max Niemeyer Verlag.
- Koenig, Jean-Pierre. 1999. *Lexical Relations*. Stanford Monographs in Linguistics, Stanford: CSLI Publications.
- Koster, Jan. 1975. Dutch as an SOV Language. *Linguistic Analysis* 1(2), 111–136.
- Krieger, Hans-Ulrich. 1994. Derivation Without Lexical Rules. In C.J. Rupp, Michael A. Rosner & Rod L. Johnson (eds.), *Constraints, Language and Computation*, Computation in Cognitive Science, pages 277–313, London/San Diego/New York: Academic Press, a version of this paper is available as DFKI Research Re-

- port RR-93-27. Also published in: IDSIA Working Paper No. 5, Lugano, November 1991.
- Krieger, Hans-Ulrich & Nerbonne, John. 1993. Feature-Based Inheritance Networks for Computational Lexicons. In Ted Briscoe, Ann Copestake & Valeria de Paiva (eds.), *Inheritance, Defaults, and the Lexicon*, pages 90–136, Cambridge: Cambridge University Press.
- Lebeth, Kai. 1994. Morphosyntaktischer Strukturaufbau – Die Generierung komplexer Verben im HPSG-Lexikon eines Sprachproduktionssystems. Hamburger Arbeitspapiere zur Sprachproduktion – IV Arbeitspapier No. 16, Universität Hamburg, Fachbereich Informatik.
- Lötscher, Andreas. 1985. Syntaktische Bedingungen der Topikalisierung. *Deutsche Sprache* 13, 207–229.
- Lüdeling, Anke. 2001. *On Particle Verbs and Similar Constructions in German*. Dissertations in Linguistics, Stanford: CSLI Publications.
- McCawley, James D. 1982. Parentheticals and Discontinuous Constituent Structure. *Linguistic Inquiry* 13(1), 91–106.
- McIntyre, Andrew. 2001a. Argument Blockages Induced by Verb Particles in English and German: Event Modification and Secondary Predication. In Nicole Dehé & Anja Wanner (eds.), *Structural Aspects of Semantically Complex Verbs*, pages 131–164, Berlin/Frankfurt/New York: Peter Lang.
- McIntyre, Andrew. 2001b. *German Double Particles as Preverbs: Morphology and Conceptual Semantics*. Studien zur deutschen Grammatik, No. 61, Tübingen: Stauffenburg Verlag.
- McIntyre, Andrew. 2001c. German Particle Verbs and Morphology. Leipzig, ms.
- Meurers, Walt Detmar. 1999. Raising Spirits (and Assigning Them Case). *Groninger Arbeiten zur Germanistischen Linguistik (GAGL)* 43, 173–226, <http://ling.osu.edu/~dm/papers/gagl99.html>. 04.18.2000.
- Meurers, Walt Detmar. 2000. Lexical Generalizations in the Syntax of German Non-Finite Constructions. Arbeitspapiere des SFB 340 No. 145, Eberhard-Karls-Universität, Tübingen, <http://www.ling.ohio-state.edu/~dm/papers/diss.html>. 08.19.2002.
- Müller, Stefan. 1997. Yet another Paper about Partial Verb Phrase Fronting in German. Research Report RR-97-07, Deutsches Forschungszentrum für Künstliche Intelligenz, Saarbrücken, a shorter version appeared in *Proceedings of COLING 96*, pages 800–805. <http://www.dfki.de/~stefan/Pub/pvp.html>. 03.14.2003.
- Müller, Stefan. 1999. *Deutsche Syntax deklarativ. Head-Driven Phrase Structure Grammar für das Deutsche*. Linguistische Arbeiten, No. 394, Tübingen: Max Niemeyer Verlag, <http://www.dfki.de/~stefan/Pub/hpsg.html>. 03.14.2003.
- Müller, Stefan. 2000. German Particle Verbs and the Predicate Complex. In Ronnie Cann, Claire Grover & Philip Miller (eds.), *Grammatical Interfaces in HPSG*, Studies in Constraint-Based Lexicalism, No. 8, pages 215–229, Stanford: CSLI Publications, <http://www.dfki.de/~stefan/Pub/part-complex.html>. 03.14.2003.
- Müller, Stefan. 2002. Syntax or Morphology: German Particle Verbs Revisited. In Nicole Dehé, Ray Jackendoff, Andrew McIntyre & Silke Urban (eds.), *Verb-Particle Explorations*, Interface Explorations, No. 1, pages 119–139, Berlin, New York: Mouton de Gruyter, <http://www.dfki.de/~stefan/Pub/syn-morph-part.html>. 03.14.2003.
- Nerbonne, John, Netter, Klaus & Pollard, Carl J. (eds.). 1994. *German in Head-Driven Phrase Structure Grammar*. CSLI Lecture Notes, No. 46, Stanford: CSLI Publications.
- Netter, Klaus. 1994. Towards a Theory of Functional Heads: German Nominal Phrases.

- In Nerbonne et. al. (1994), pages 297–340.
- Netter, Klaus. 1998. *Functional Categories in an HPSG for German*. Saarbrücken Dissertations in Computational Linguistics and Language Technology, No. 3, Saarbrücken: German Research Center for Artificial Intelligence (DFKI) and University of the Saarland.
- Nunberg, Geoffrey, Sag, Ivan A. & Wasow, Thomas. 1994. Idioms. *Language* 70(3), 491–538.
- Olsen, Susan. 1991. *Ge-Präfigierung im heutigen Deutsch – Ausnahmen von der Right-hand Head Rule?* *Beiträge zur Geschichte der deutschen Sprache* 113, 333–366.
- Olsen, Susan. 1997. Prädikative Argumente syntaktischer und lexikalischer Köpfe: Zum Status der Partikelverben im Deutschen und Englischen. *Folia Linguistica* 31, 3–4.
- Olsen, Susan. 1999. Verbpartikel oder Adverb. In Angelika Redder & Jochen Rehbein (eds.), *Grammatik und mentale Prozesse*, Stauffenburg Linguistik, pages 223–239, Tübingen: Stauffenburg Verlag.
- Olszok, Klaus. 1983. Infinite Formen im Vorfeld. In Klaus Olszok & Edith Weuster (eds.), *Zur Wortstellungsproblematik im Deutschen*, Studien zur Deutschen Grammatik, No. 20, pages 89–169, Tübingen: Gunter Narr Verlag.
- Orgun, Cemil Orhan. 1996. *Sign-Based Morphology and Phonology*. Ph. D.thesis, University of California, Berkeley.
- Paul, Hermann. 1920. *Deutsche Grammatik. Teil V: Wortbildungslehre*, volume 5. Halle an der Saale: Max Niemeyer Verlag, 2nd unchanged edition 1968, Tübingen: Max Niemeyer Verlag.
- Pesetsky, David Michael. 1985. Morphology and Logical Form. *Linguistic Inquiry* 16(2), 193–246.
- Pollard, Carl J. 1996. On Head Non-Movement. In Bunt & van Horck (1996), pages 279–305, veröffentlichte Version eines Ms. von 1990.
- Pollard, Carl J. & Sag, Ivan A. 1987. *Information-Based Syntax and Semantics*. CSLI Lecture Notes, No. 13, Stanford: CSLI Publications.
- Pollard, Carl J. & Sag, Ivan A. 1994. *Head-Driven Phrase Structure Grammar*. Studies in Contemporary Linguistics, Chicago, London: University of Chicago Press.
- Przepiórkowski, Adam. 1999. On Case Assignment and “Adjuncts as Complements”. In Gert Webelhuth, Jean-Pierre Koenig & Andreas Kathol (eds.), *Lexical and Constructional Aspects of Linguistic Explanation*, Studies in Constraint-Based Lexicalism, No. 1, pages 231–245, Stanford: CSLI Publications.
- Reape, Mike. 1992. *A Formal Theory of Word Order: A Case Study in West Germanic*. Ph. D.thesis, University of Edinburgh.
- Reape, Mike. 1994. Domain Union and Word Order Variation in German. In Nerbonne et. al. (1994), pages 151–198.
- Reape, Mike. 1996. Getting Things in Order. In Bunt & van Horck (1996), pages 209–253, published version of a Ms. dated January 1990.
- Reis, Marga. 1976. Reflexivierungen in deutschen A.c.I-Konstruktionen. Ein transformationsgrammatisches Dilemma. *Papiere zur Linguistik* 9, 5–82.
- Rentier, Gerrit. 1994. Dutch Cross Serial Dependencies in HPSG. In *Proceedings of COLING 94*, pages 818–822, Kyoto, Japan.
- Riehemann, Susanne Z. 1998. Type-Based Derivational Morphology. *Journal of Comparative Germanic Linguistics* 2, 49–77.
- Sag, Ivan A. & Wasow, Thomas. 1999. *Syntactic Theory: A Formal Introduction*. Stanford: CSLI Publications, <http://csli-publications.stanford.edu/site/1575861607.html>. 08.18.2002.

- Spencer, Andrew J. 1988. Bracketing Paradoxes and the English Lexicon. *Language* 64(4), 663–682.
- Stiebels, Barbara. 1996. *Lexikalische Argumente und Adjunkte: Zum semantischen Beitrag verbaler Präfixe und Partikeln*. *studia grammatica* XXXIX, Berlin: Akademie Verlag.
- Stiebels, Barbara & Wunderlich, Dieter. 1994. Morphology Feeds Syntax: the Case of Particle Verbs. *Linguistics* 32(6), 913–968.
- Stump, Gregory T. 1991. A Paradigm-Based Theory of Morphosemantic Mismatches. *Language* 67(4), 675–725.
- Trost, Harald. 1991. Recognition and Generation of Word Forms for Natural Language Understanding Systems: Integrating Two-Level Morphology and Feature Unification. *Applied Artificial Intelligence* 5, 411–457.
- Trost, Harald. 1993. Coping with Derivation in a Morphological Component. In *Proceedings of the Sixth Conference of the European Chapter of the Association for Computational Linguistics*, pages 368–376, Utrecht.
- van Eynde, Frank. 1994. *Auxiliaries and Verbal Affixes—A Monostratal Cross-linguistic Analysis*. Katholieke Universiteit Leuven, Faculteit Letteren, Departement Linguïstiek, proefschrift.
- van Noord, Gertjan & Bouma, Gosse. 1994. The Scope of Adjuncts and the Processing of Lexical Rules. In COLING Staff (ed.), *Proceedings of COLING 94*, pages 250–256, Kyoto, Japan: ACL – Association for Computational Linguistics, <http://grid.let.rug.nl/~vannoord/papers/coling94.ps.gz>. 08.18.2002.
- Wells, Rulon S. 1947. Immediate Constituents. *Language* 23, 81–117, reprinted in M. Joos, ed, *Readings in Linguistics I*, University of Chicago Press, Chicago, 1958, 186–207.
- Werner, Otmar. 1994. Was da sich öles aahotmüßhör! ,Was der sich alles hat anhören müssen!‘ Auxiliar-Inkorporation im Ostfränkisch-Thüringischen. In Heinrich Löffler, Karlheinz Jakob & Bernhard Kelle (eds.), *Texttyp, Sprechergruppe, Kommunikationsbereich. Studien zur deutschen Sprache in Geschichte und Gegenwart. Festschrift für Hugo Steger zum 65. Geburtstag*, pages 343–361, Berlin, New York: Walter de Gruyter.
- Williams, Edwin. 1981. On the Notions “Lexically Related” and “Head of a Word”. *Linguistic Inquiry* 12(2), 245–274.
- Yip, Moira, Maling, Joan & Jackendoff, Ray. 1987. Case in Tiers. *Language* 63(2), 217–250.
- Zifonun, Gisela. 1999. Wenn *mit* alleine im Mittelfeld erscheint: Verbpartikeln und ihre Doppelgänger im Deutschen und Englischen. In Heide Wegener (ed.), *Deutsch kontrastiv. Typologisch-vergleichende Untersuchungen zur deutschen Grammatik*, Stauffenberg Verlag.

Author's adress: Stefan Müller
Lehrstuhl für Germanistische Linguistik/Computerlinguistik
Institut für Germanistische Sprachwissenschaft
Friedrich-Schiller-Universität Jena
Fürstengraben 30
D-07740 Jena
E-mail: Stefan.Mueller@dfki.de